

**STANLEY**

## GARAGE DOOR OPENER INSTRUCTION MANUAL

FOR USE ON MOST TYPES OF GARAGE DOORS

- **DO NOT THROW THIS MANUAL AWAY.**  
Keep in a safe location for future reference.
- **Do not connect to power until instructed to do so.**
- **Do not run door opener until completely installed.**
- **Door opener will not operate until beam sensor is installed and properly aligned.**
- **For your protection, wear safety glasses.**

**Read and follow ALL instructions carefully.**

**[www.stanley-garage-opener.com](http://www.stanley-garage-opener.com)**

For technical questions or to place orders by phone, please call us at (800)849-3998 Mon-Fri 9am-5pm & Saturdays 9am-1pm Pacific Time, international calls use (818)725-7125

021.0349B

# IMPORTANT INSTALLATION INSTRUCTIONS

Dear Homeowner,

Please read the following **IMPORTANT INSTALLATION INSTRUCTIONS** before beginning assembly and installation.



**THIS CAUTION SYMBOL APPEARS PERIODICALLY THROUGHOUT THIS MANUAL. IT WILL IDENTIFY IMPORTANT SAFETY INSTRUCTIONS.**

– These safety instructions must be followed  
to persons  
installing, using or in the vicinity of the garage door or garage door opener.

A. BE SURE TO READ AND FOLLOW ALL INSTALLATION INSTRUCTIONS.

B. INSTALL THE GARAGE DOOR OPENER ONLY ON A PROPERLY BALANCED AND LUBRICATED GARAGE DOOR. AN IMPROPERLY BALANCED DOOR COULD CAUSE SEVERE INJURY.

LUBRICATE YOUR DOOR BY APPLYING A LIGHT OIL OR SILICONE LUBRICANT TO THE DOOR HINGES, MOUNTING HARDWARE AND THE ROLLER BEARINGS. YOUR DOOR SHOULD MOVE FREELY BY HAND WITHOUT STICKING OR BINDING. DO NOT APPLY OIL OR GREASE TO THE ROLLER TRACKS. CONDUCT DOOR BALANCE TEST BEFORE BEGINNING INSTALLATION.

## DOOR BALANCE TEST

Raise your door to its mid-point and release it. The door should remain in this position without moving up or down.

Next, move the door to the 3/4 open position and release it. The door should remain in place or move slowly to the full open position.

Finally, move the door to the 3/4 close position and release it. The door should remain in place or move slowly to the full close position.

If the door fails any of these three door tests, the springs may be out of adjustment. Have a qualified service person make repairs to cables, spring assemblies and other hardware before installing the opener. Some parts are under EXTREME tension at times and can cause serious injury if improperly handled.

C. REMOVE ALL ROPES AND REMOVE OR MAKE INOPERATIVE ALL LOCKS CONNECTED TO THE GARAGE DOOR BEFORE INSTALLING OPENER. ACCIDENTAL ENGAGEMENT OF DOOR LOCKS MAY RESULT IN DAMAGE TO DOOR OR OPENER AND POSSIBLE PERSONAL INJURY.

D. IF POSSIBLE, INSTALL DOOR OPENER 7 FEET OR MORE ABOVE THE FLOOR. THIS MAY NOT BE POSSIBLE WITH MOST ONE-PIECE DOORS. IN THIS CASE INDIVIDUALS OVER 6 FOOT SHOULD BE ALERT TO THIS POTENTIAL OBSTACLE WHILE IN THE GARAGE.

E. MOUNT THE RED EMERGENCY RELEASE KNOB 6 FEET ABOVE THE FLOOR. IT SHOULD BE REACHABLE BY ADULTS IN THE HOUSEHOLD TO ALLOW MANUAL USE OF THE GARAGE DOOR IN AN EMERGENCY.

F. DO NOT CONNECT OPENER TO POWER SOURCE UNTIL INSTRUCTED TO DO SO. EXTENSION CORDS SHOULD NOT BE USED. THE OPENER MUST BE PLUGGED INTO A PROPERLY-GROUNDED 120 VOLT THREE-PRONG OUTLET.

G. LOCATE THE WALL MOUNTED PUSHBUTTON WITHIN SIGHT OF THE DOOR AND AT A MINIMUM HEIGHT OF 5 FEET ABOVE THE FLOOR SO SMALL CHILDREN CANNOT REACH IT. MOUNT IT AWAY FROM ALL MOVING PARTS OF THE DOOR.

H. BE SURE TO INSTALL THE **ENTRAPMENT WARNING LABEL** NEXT TO THE CONTROL BUTTON. READ THE **CONTROL ADJUSTMENT WARNING LABEL** ON THE REAR OF THE OPENER AND ALSO THE **EMERGENCY RELEASE TAG**, WHICH IS INSTALLED ON THE EMERGENCY RELEASE CORD OF THE TRAVELER.

I. AFTER INSTALLING DOOR OPENER, THE DOOR MUST REVERSE WHEN IT COMES IN CONTACT WITH A 1-1/2 INCH HIGH OBJECT (OR A 2x4 BOARD LAID FLAT ON THE FLOOR). CHECK THE SAFETY REVERSING MECHANISM OFTEN (ONCE A MONTH IS RECOMMENDED) TO ENSURE IT REVERSES WITH A MINIMUM AMOUNT OF FORCE. THIS MUST BE RETESTED ANY TIME AN ADJUSTMENT IS MADE TO THE DOOR ARM, FORCE ADJUSTMENTS, OR CLOSED POSITION ADJUSTMENT.

J. IF DAMAGE TO ANY MECHANICAL DRIVE OR STRUCTURAL COMPONENT OF UNIT IS OBSERVED DISCONTINUE USE AND CONTACT AN AUTHORIZED GARAGE DOOR/DOOR OPENER DEALER OR THE CONSUMER SERVICE DEPARTMENT IMMEDIATELY.

IF YOU SELECT **TOO MUCH** DOOR FORCE, OR DID NOT PROPERLY REINFORCE YOUR DOOR (IF REQUIRED) AS INSTRUCTED, YOU MAY SEVERELY DAMAGE YOUR GARAGE DOOR AND DOOR OPENER. **ALWAYS** SELECT THE LOWEST FORCE POSSIBLE TO OPERATE YOUR DOOR.

**NEVER OPERATE THE OPENER IF THE SYSTEM IS NOT FUNCTIONING PROPERLY OR IF IT WILL NOT REVERSE OFF OF A 1-1/2 INCH HIGH OBJECT. CONDUCT ALL SAFETY REVERSE TESTS AT LEAST TWICE.**

# FEATURES

## CONTROLS

To operate door, press either the hand held transmitter button or wall mounted pushbutton for one to two seconds. The door will automatically open or close. Door can be stopped during any portion of the opening or closing cycle by pressing either of the buttons. The next time the button is pressed, the door will move in the opposite direction.

## SAFE-T-MONITOR™

The opener electronically selects the minimum force required to operate the door. The opener selects the user adjustable force level the first cycle after an obstruction as described in the next section.

## FORCE ADJUSTMENTS

Independent OPEN and CLOSE dials allow you to select the minimum force required to open and close the door. When properly adjusted, door will automatically reverse if it senses an obstruction while closing and stop if it hits an obstacle when opening.

## SAFE-T-CYCLE™

This system will reverse a closing door in 30 seconds or less if door is unable to travel to the fully closed position.

## EMERGENCY RELEASE

Your door opener is equipped with an emergency release device. To disconnect door from opener, pull emergency release cord down allowing disconnect to latch. This will allow you to manually open or close the door. To reconnect door to opener, pull emergency release cord away from door and allow traveler to latch. By operating power unit, the traveler will automatically reconnect.

## CONTROL CONNECTIONS

All openers are provided with two screw terminals for the attachment of a wall mounted pushbutton or four-function wall console. A two pin plug is also provided to connect the Beam Sensor to the power unit.

**Opener will not operate until Beam Sensor is connected and aligned.**

# SPECIFICATIONS

**Voltage Required:** 120 Volts - 60 Hz - 7A - 1PH.  
A grounded, three (3) hole electrical outlet is required.

## WARNING - FIRE AND ENTRAPMENT PROTECTION

**Overload Protection:** Motor is equipped with automatic thermal overload device to reduce risk of fire as required by U.L. 2111. This prevents the motor from operating if overheated. **THERMAL OVERLOAD WILL TEMPORARILY DEFEAT AUTOMATIC REVERSING FUNCTIONS. USE EMERGENCY RELEASE TO OPEN DOOR IN CASE OF THERMAL OVERLOAD.** Motor will cool after 5 to 10 minutes and operation will resume.

**Opener Length:** 10 Feet - 9 Inches  
From end of tube assembly to rear of opener power unit.

**Minimum Head Room Required:** 2 Inches (Tracked Doors)  
6 Inches (Trackless Doors)

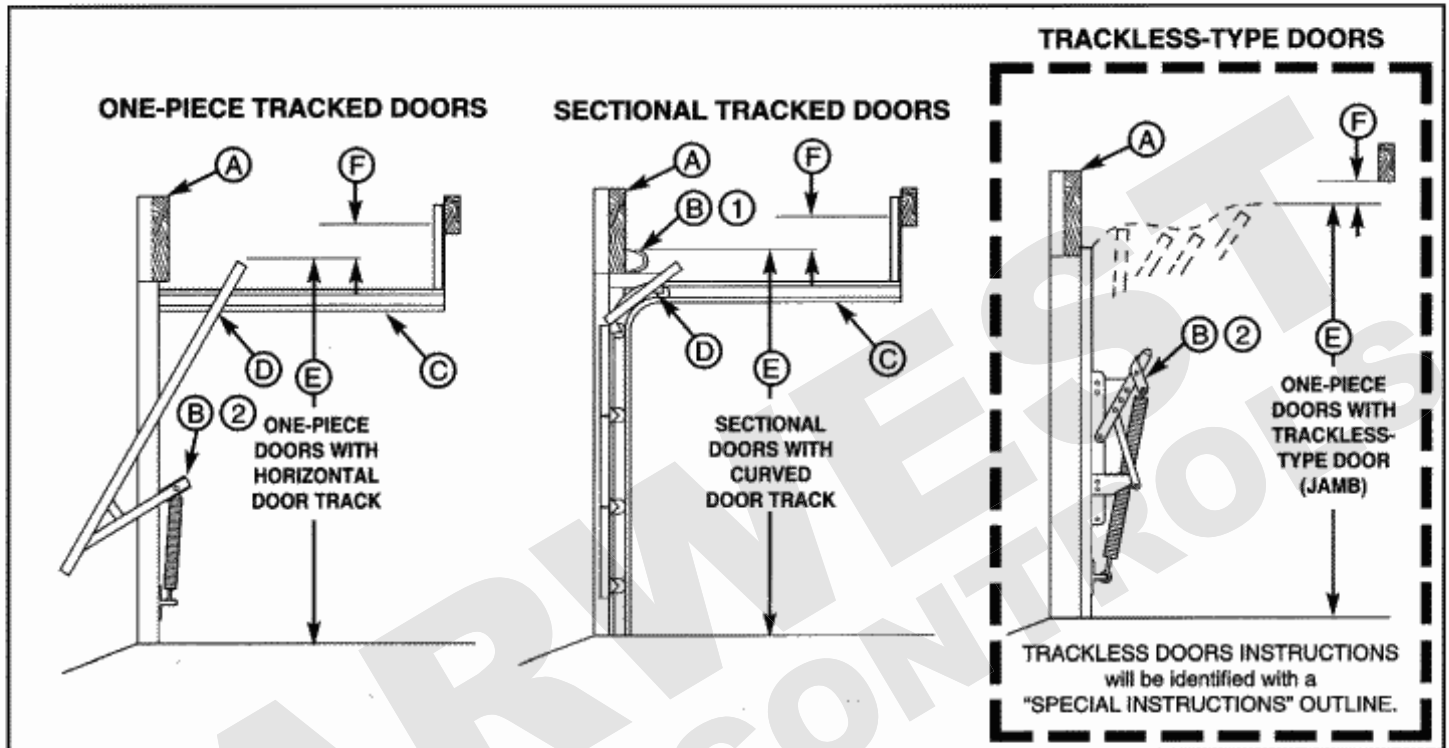
**Average Door Speed:** 7 Inches per second

# DOOR & OPENER TERMINOLOGY



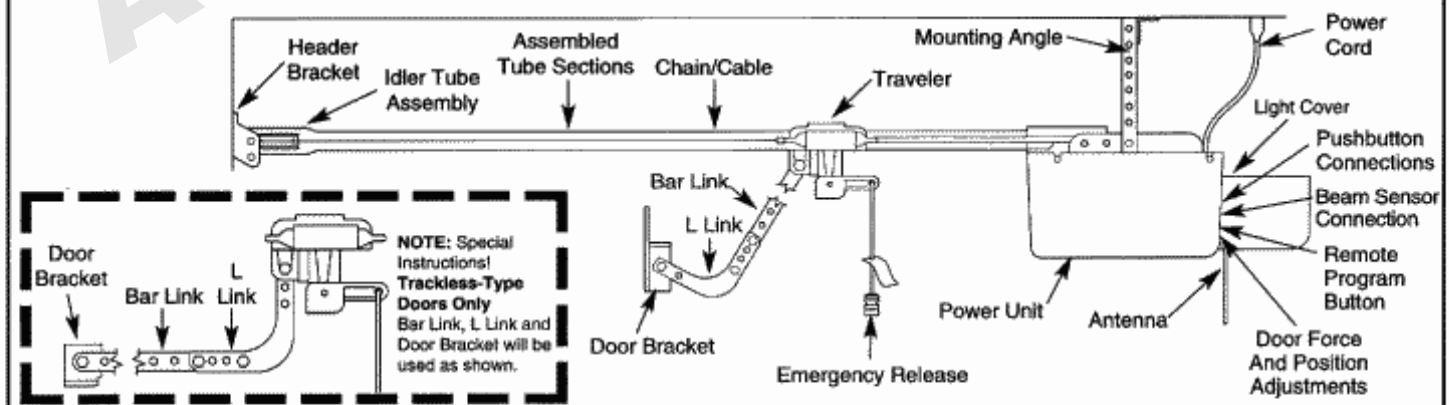
**WARNING:** This garage door opener is intended for use on one of the types of doors shown below **ONLY**. It is **UNSAFE** to attempt installation on any other type of door or moving mechanism.

Use the illustrations below to determine the major components of your garage door. Before you begin assembly, review the mounting procedure on page 11, to help you plan out, ahead of time, a means of securing the power unit.



- (A) DOOR HEADER** – The wood or metal beam positioned horizontally across the top of garage doorway.
- (B) DOOR SPRING** – Springs used to balance the door. B1 – Torsion spring, B2 - Extension spring.
- (C) DOOR TRACKS** - Metal guides to allow door to travel a straight path. Not used on trackless doors.
- (D) DOOR ROLLERS** - Attached to door and follow inside the door tracks. Not used on trackless doors.
- (E) HIGH-RISE** - The highest point the top of door reaches when opening.
- (F) HEAD ROOM** - Area between high rise of door or the door spring and the bottom of rafters or finished ceilings. Do not attempt assembly with less than 2 inches of head room.

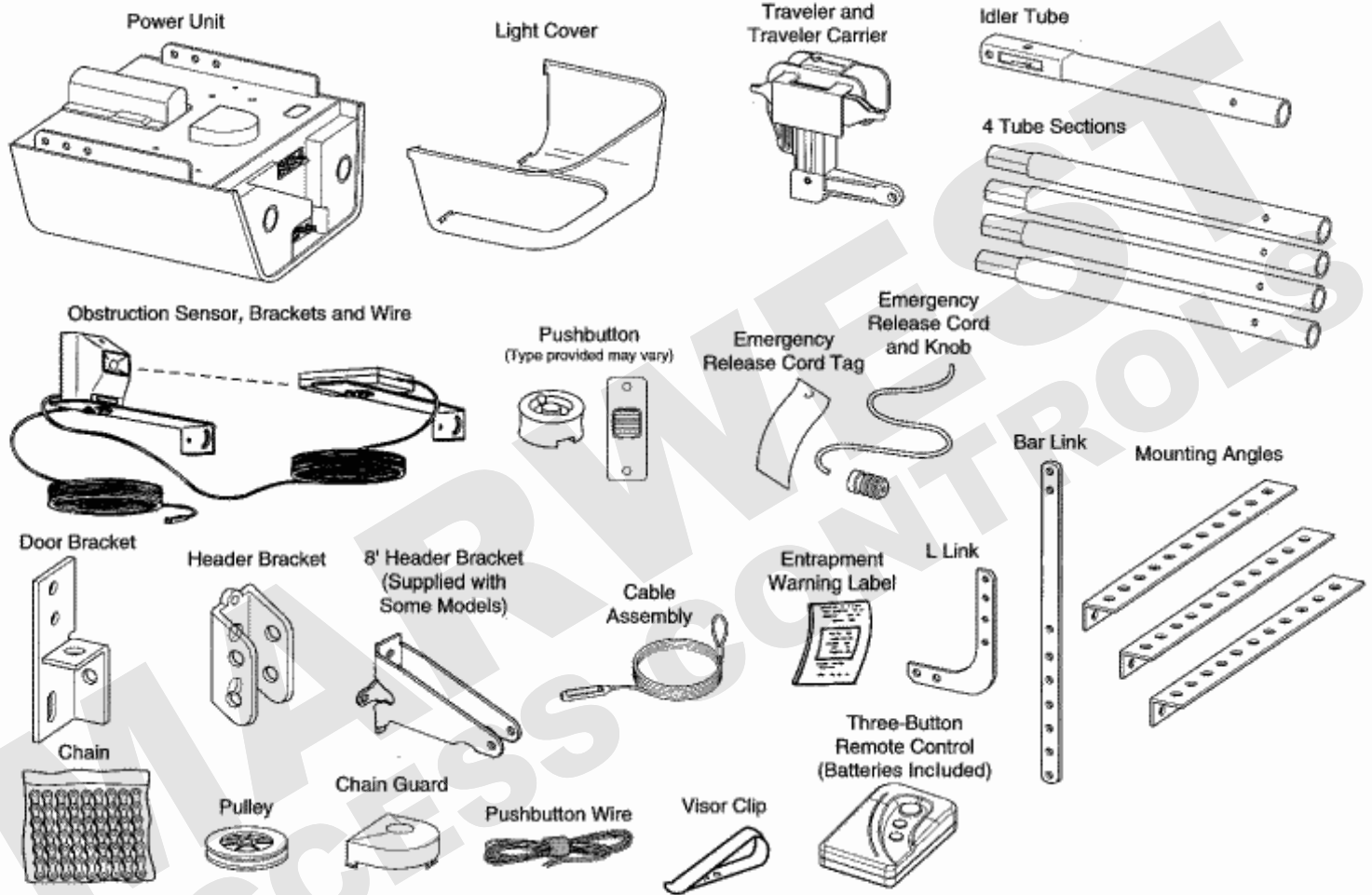
To become more familiar with your garage door opener, review the following illustration and terminology of an installed opener.



# COMPONENTS & TOOLS

CAREFULLY INSPECT YOUR NEW GARAGE DOOR OPENER FOR ANY POSSIBLE DAMAGE AND/OR SHORT-AGE OF PARTS. SEPARATE ALL PARTS, FASTENERS AND ACCESSORIES AS CALLED OUT BELOW. DO NOT ATTEMPT INSTALLATION IF PARTS ARE DAMAGED OR MISSING. IN THE EVENT THAT YOU HAVE DAMAGED OR MISSING PARTS, THERE IS NO NEED TO RETURN THE PRODUCT. PLEASE CALL PHONE NUMBER ON COVER, AND WE WILL IMMEDIATELY SHIP THE NECESSARY PARTS.

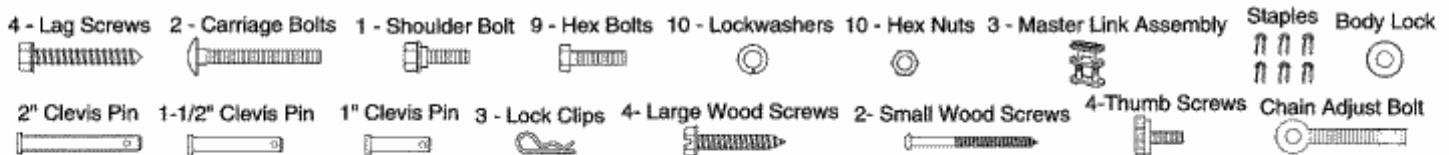
## MAJOR COMPONENTS



## TOOLS REQUIRED BOXES

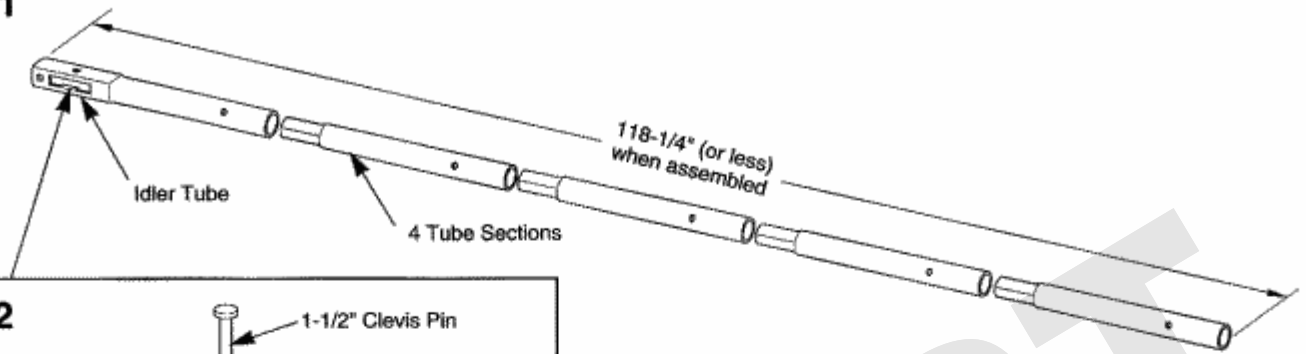


## FASTENERS

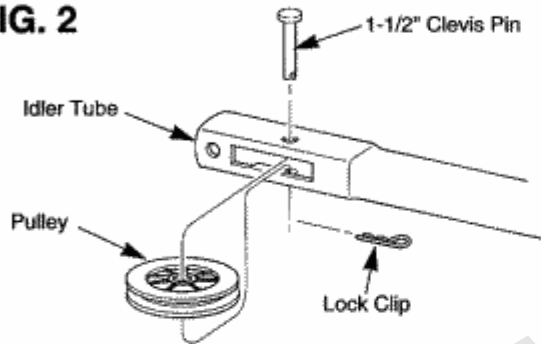


# ASSEMBLY

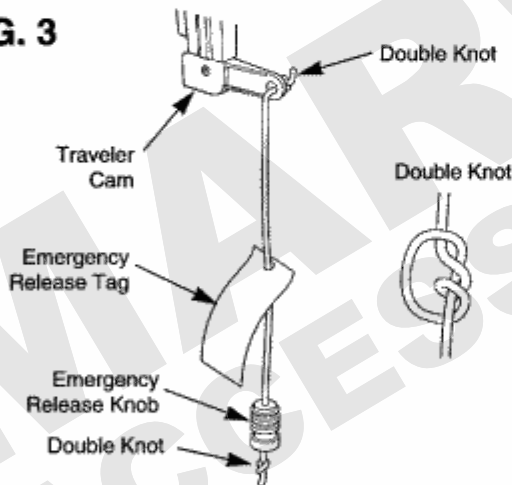
**FIG. 1**



**FIG. 2**



**FIG. 3**



To protect power unit during assembly, use cardboard packing panels. Locate remote control inside packing material and set it aside in a safe place.

A. Assemble the 5 tube sections as shown in Fig. 1.

**MAKE CERTAIN THAT THE TUBE SECTIONS ARE FULLY SEATED.**

The "End To End" length must be 118-1/4" (or less).  
(You may need to gently tap them together.)

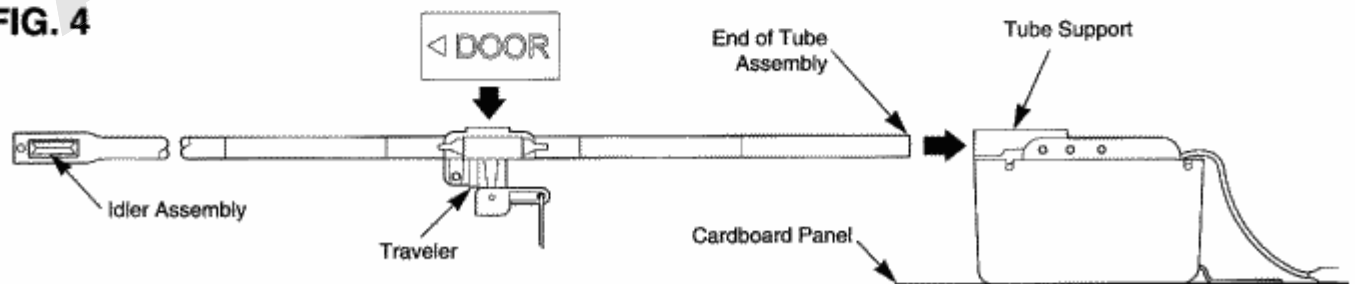
B. Attach pulley to end of tube using the one and one half inch (1-1/2") clevis pin and a lock clip. See Fig. 2.

C. Tie a double knot in one end of red emergency release cord. Attach knob and emergency release tag. Attach other end of red emergency release cord to traveler cam using another double knot. See Fig. 3.

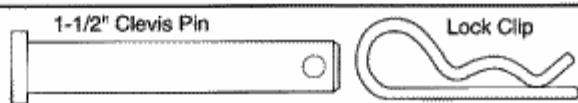
D. Slide traveler onto tube assembly. Make sure (DOOR) arrow on traveler points toward idler assembly.

E. Insert end of tube assembly into tube support on top of power unit. See Fig. 4.

**FIG. 4**

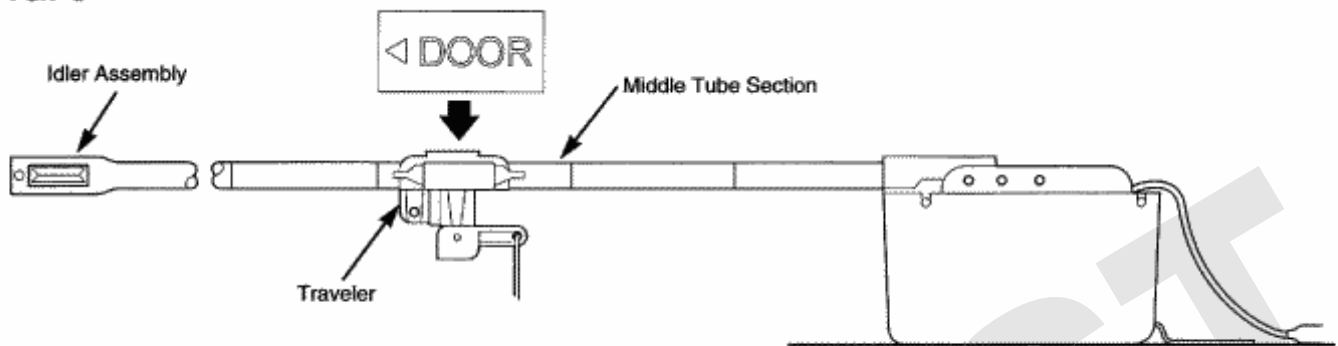


**FASTENERS USED ON THIS PAGE:**



# ASSEMBLY (CONTINUED)

FIG. 5



- F. Position traveler on middle tube section. See Fig. 5.
- G. Using master link assembly, secure loose end of chain to traveler carrier. **Fasten retaining clip on top.** See Fig. 6.
- H. Loop chain around drive sprocket on top of power unit. Make sure traveler remains on middle tube section. If not, reloop chain around drive sprocket. See Fig. 7.

FIG. 6

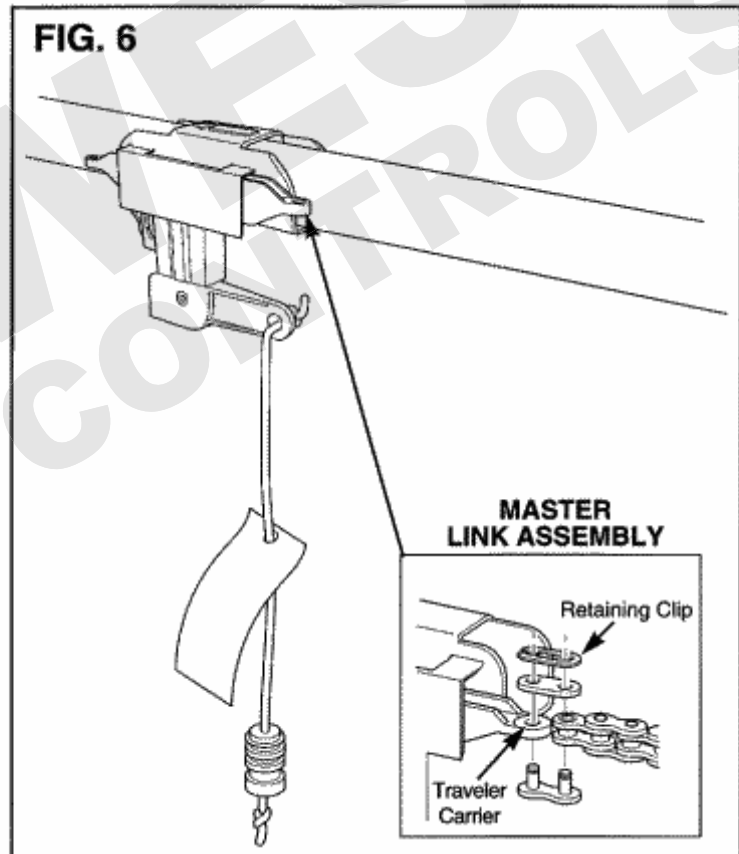
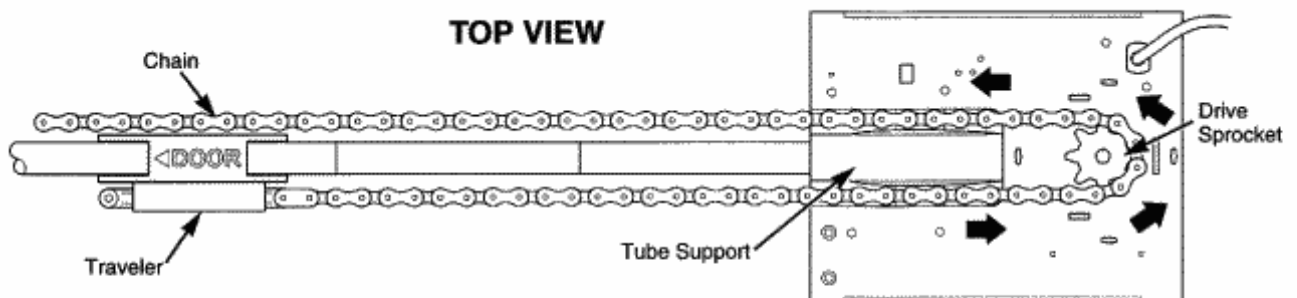


FIG. 7

TOP VIEW

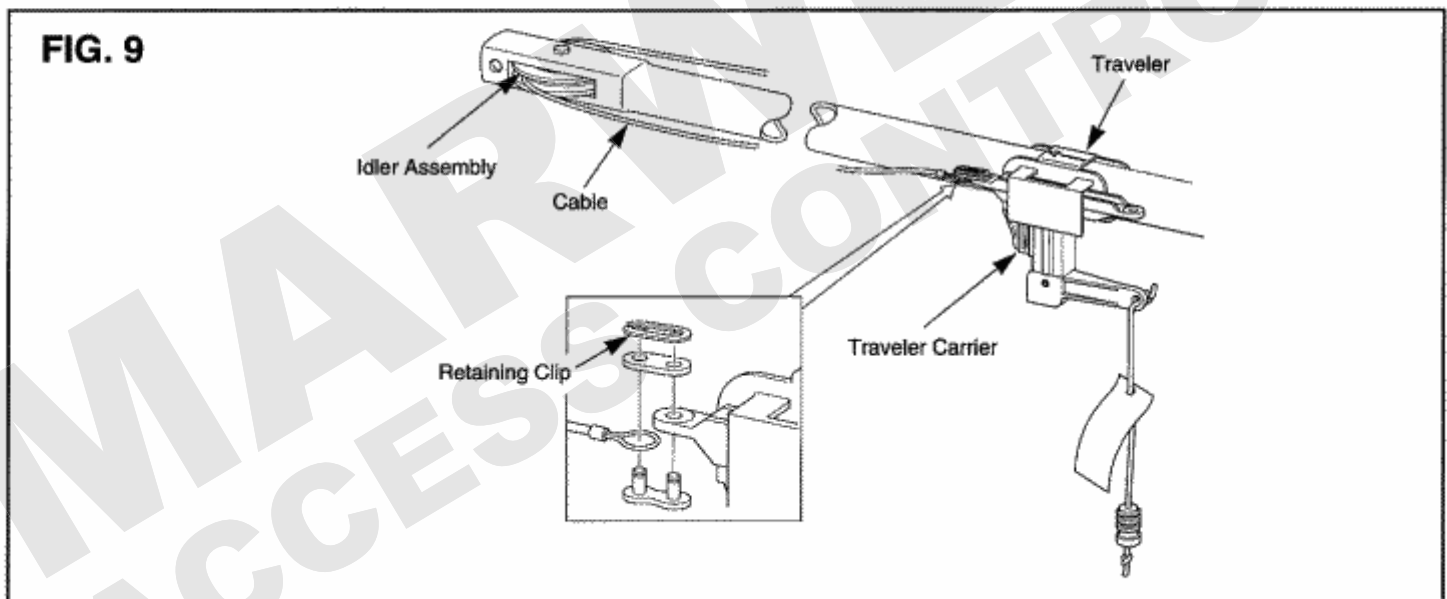
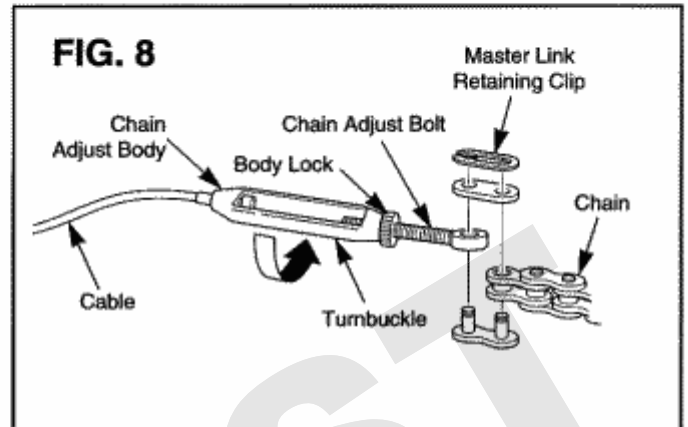


# ASSEMBLY (CONTINUED)

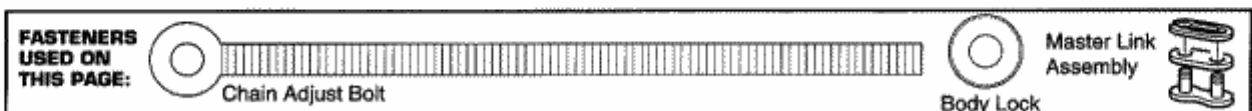
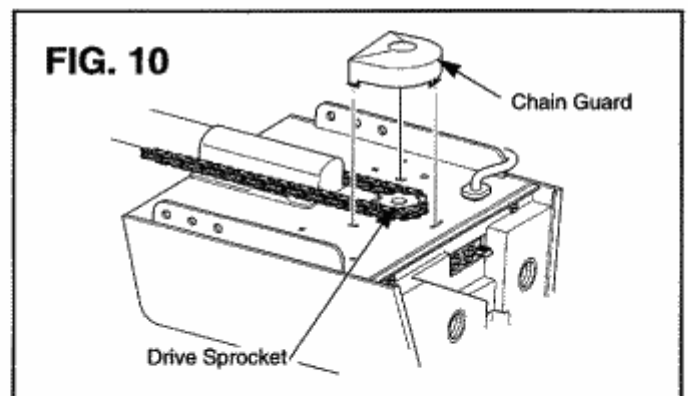
- I. Secure other end of chain to chain adjust bolt with a master link assembly. **Fasten retaining clip on top.** See Fig. 8.
- J. Thread body lock nut all the way onto chain adjust bolt.
- K. Locate cable assembly, then thread chain adjust body onto chain adjust bolt approximately four full turns.
- L. Pull loose end of cable through idler assembly until it can be attached to other side of traveler carrier. See Fig. 9.
- M. Secure cable to traveler carrier with master link assembly. **Fasten retaining clip on top.**
- N. Turn chain adjust body by hand in direction shown until chain is tight. Chain should not sag below bottom of tube.

**IMPORTANT: Do not allow cable to twist.**

- O. Securely tighten body lock nut against chain adjust body to prevent the assembly from loosening. Use pliers if necessary. See Fig. 8 again.



- P. Install chain guard over drive sprocket by pressing down until tabs snap into frame. See Fig. 10.

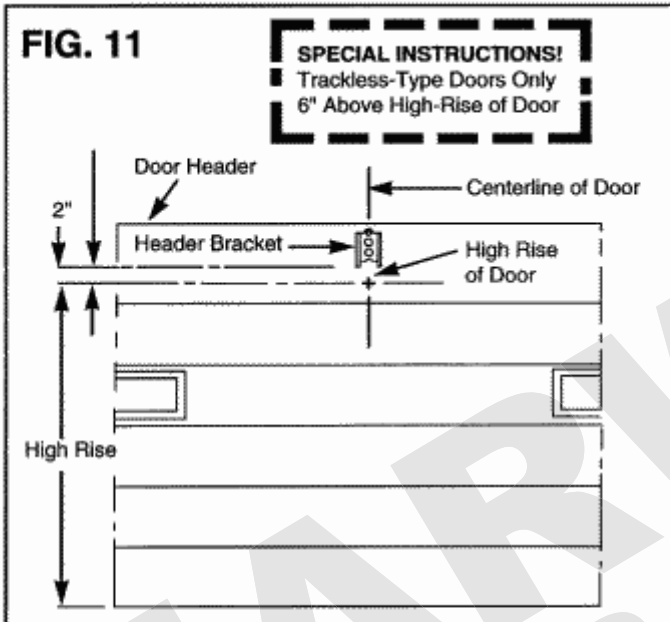




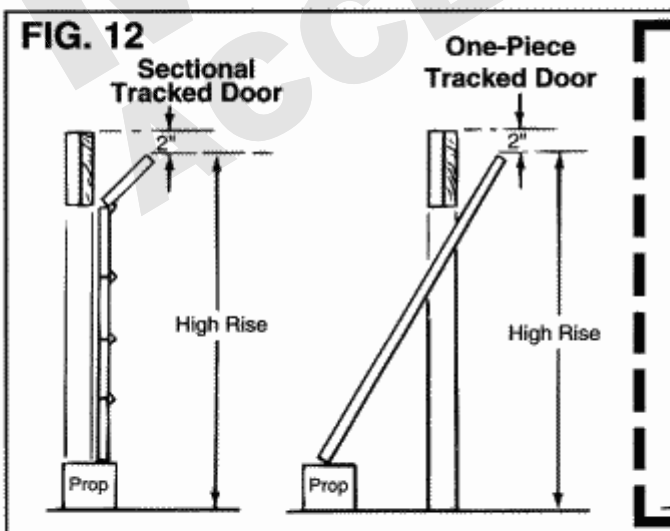
# INSTALLATION

**IMPORTANT! IT IS CRITICAL THAT YOU IDENTIFY WHAT TYPE OF DOOR YOU HAVE, AS IT WILL MAKE A DIFFERENCE IN THE WAY YOUR OPENER IS INSTALLED. SEE PAGE 4.**

- A. Mark the centerline of door on header above door and on top of door. See Fig. 11.
- B. Slowly raise door. When it reaches its **high-rise** point (highest distance off the ground when door is opening), place a support (prop) under door to hold it at that position. Measure distance from floor to top edge of door. See Fig. 12. Remove support and lower door.



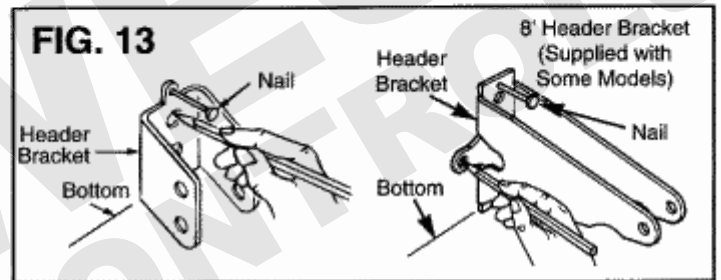
- C. Add two (2) inches to the distance measured for high-rise for **Tracked-Type Doors**.  
Add six (6) inches to the distance measured for high-rise for **Trackless-Type Doors**.



- D. Using this figure, measure from floor and mark that point on door header. Locate bottom of header bracket at that point and directly on centerline mark. (**Header bracket may be mounted higher, but do not mount any lower.**) See Fig. 13.

**IMPORTANT: SOME MODELS ARE SUPPLIED WITH AN 8' HEADER BRACKET FOR USE ON 8' HIGH DOORS. IF YOUR MODEL IS SUPPLIED WITH THIS BRACKET, PLEASE LOCATE IT NOW ALONG WITH THE 8' HEADER BRACKET MOUNTING INSTRUCTIONS THAT ARE PACKAGED SEPARATELY. FOLLOW THESE INSTRUCTIONS; THEN CONTINUE ON TO PAGE 10 IN THE MANUAL.**

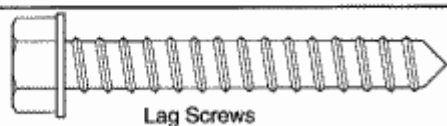
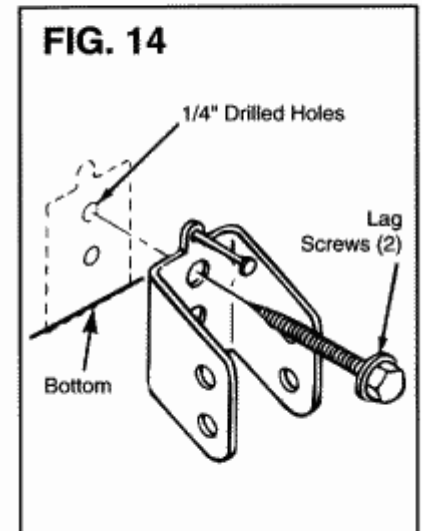
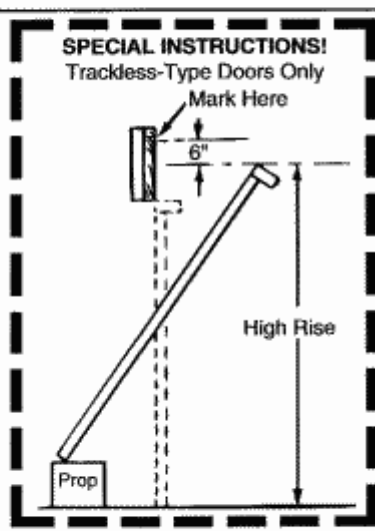
- E. Holding header bracket securely in position, mark holes on door header. A nail may be used to temporarily hold header bracket in place. See Fig. 13.



- F. With marks as guide, use a 1/4" drill bit to drill pilot holes in door header. See Fig. 14.

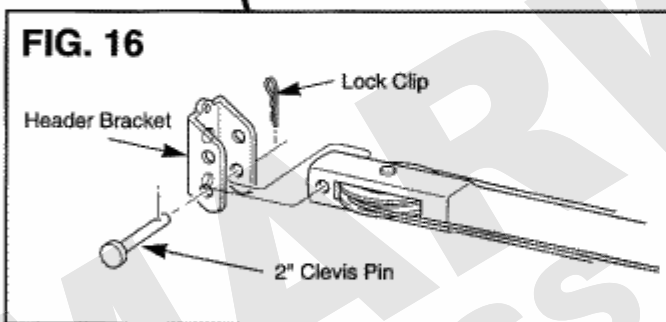
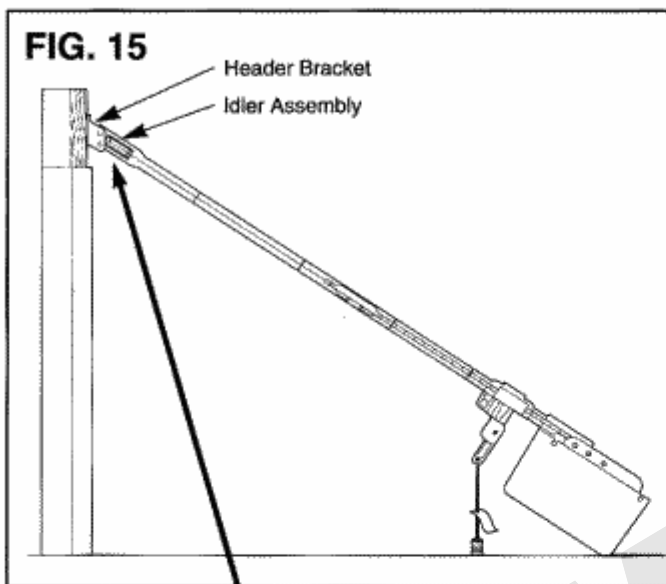
- G. Secure header bracket to door header with two lag screws. Make sure bracket is tightly secured.

**NOTE:** In some types of garages, there may be a steel channel across door header. If channel is there, drill 5/16" holes in channel, and 1/4" holes in door header.



# INSTALLATION (CONTINUED)

H. Place power unit on floor and raise idler assembly up to header bracket. See Fig. 15.

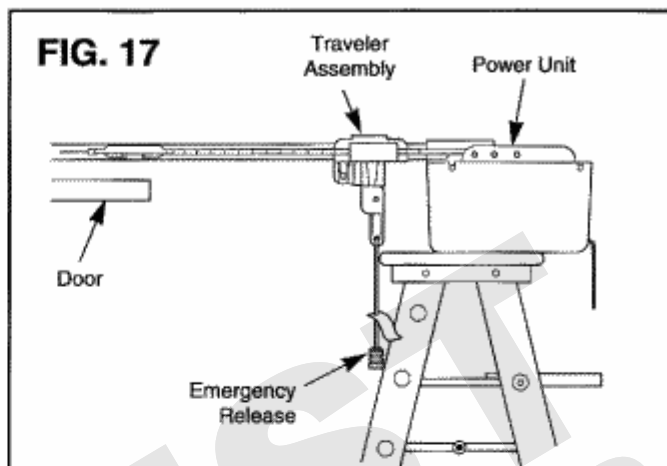


I. Use the 2" clevis pin and a lock clip to secure idler assembly to header bracket. See Fig. 16.

**NOTE:** Header bracket has additional positioning holes if height adjustment is necessary. It can also be mounted upside down for further adjustment.

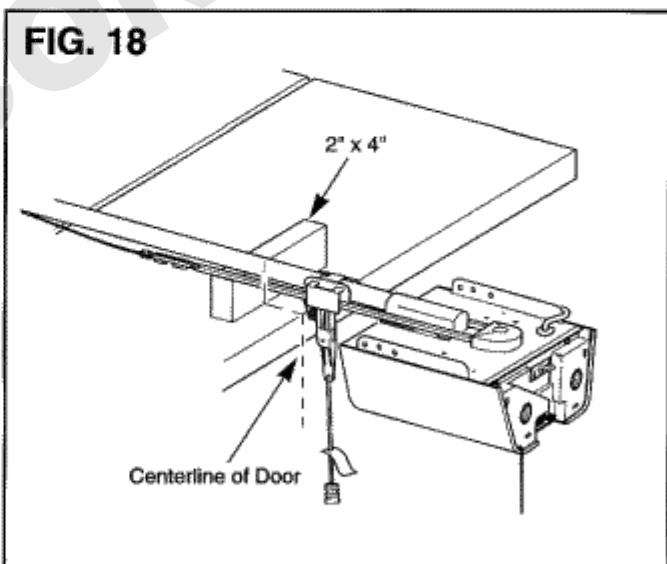
J. Carefully raise power unit and set it on a ladder or other suitable prop. Unit should be high enough to clear fully opened door.

K. Pull emergency release cord down and slide traveler toward power unit. See Fig. 17.

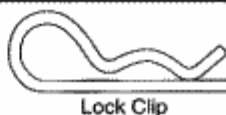
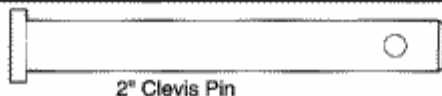


## ONE-PIECE AND SECTIONAL TRACKED DOORS ONLY

L. Raise door to full open position and place a 2" x 4" board (on edge) between tube and door. The 2" x 4" ensures that tube assembly has enough clearance when door is opening. Tube should rest on 2" x 4" directly in line with center of door. See Fig. 18.



**FASTENERS USED ON THIS PAGE:**



# INSTALLATION (CONTINUED)

FIG. 19

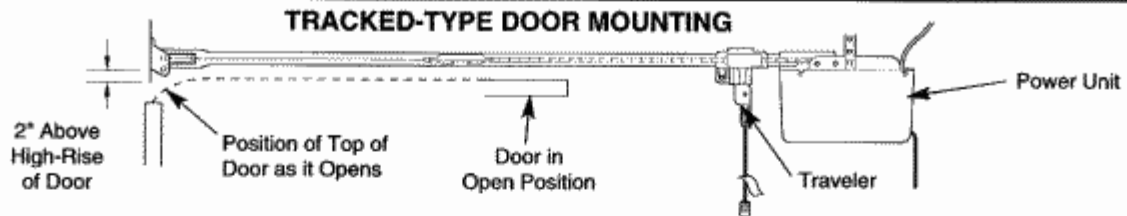


FIG. 20

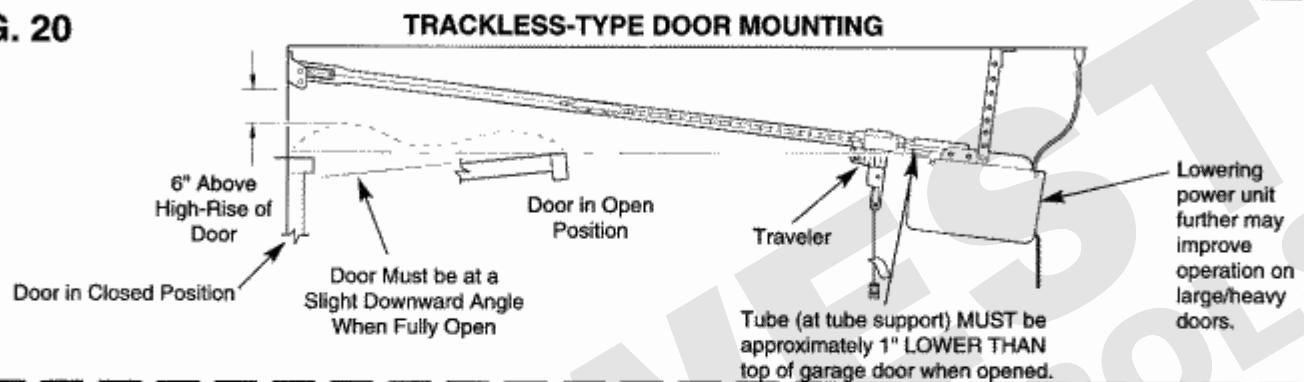
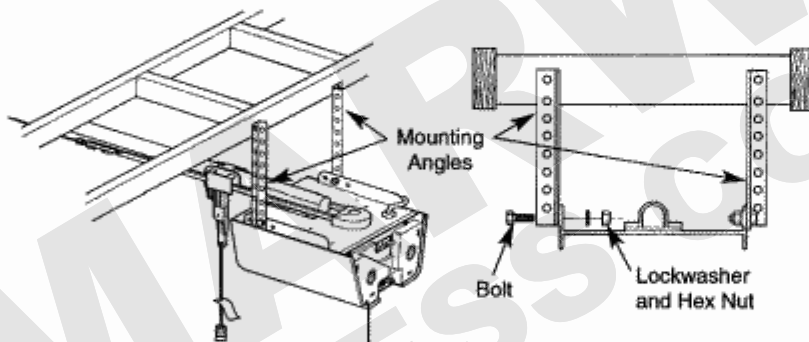
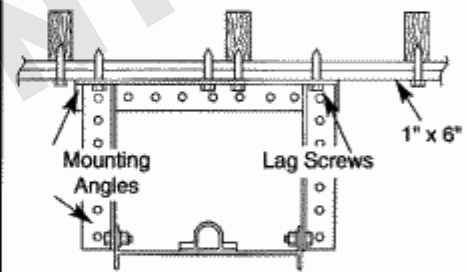


FIG. 21

**GARAGE WITH OPEN BEAMS**



**GARAGE WITH FINISHED CEILING**



## SECURING POWER UNIT

**General Information:** Mounting instructions for power unit must be somewhat general, due to the many different ceiling designs. Due to these differences, every power unit installation could be slightly different.

Basic carpentry procedures, coupled with a little pre-planning, should be all that is required to mount power unit. A local carpenter can be contacted to provide whatever assistance is required.

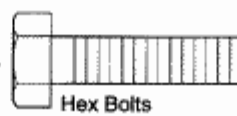


**The main concern in mounting power unit is that the installation be securely mounted for operational strength, rigidity and safety. See Figs. 19 and 20.**

M. Mount power unit to an overhead beam or ceiling. See Fig. 21 for typical mounting suggestions. Use lag screws, hex head bolts, hex nuts and lockwashers. (Lag screws are for use in overhead wood beams or ceilings; hex head bolts, lockwashers, and nuts are for mounting angles). Additional 2" x 4"s may be needed for proper installation.

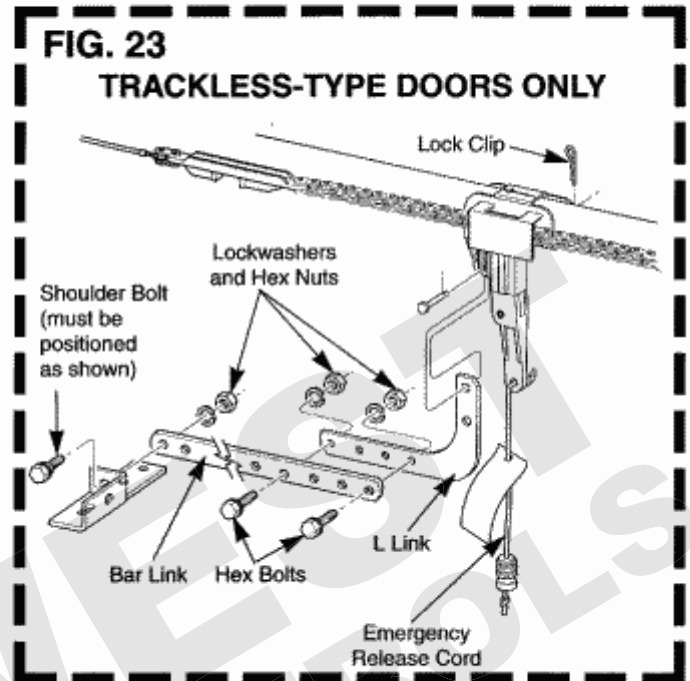
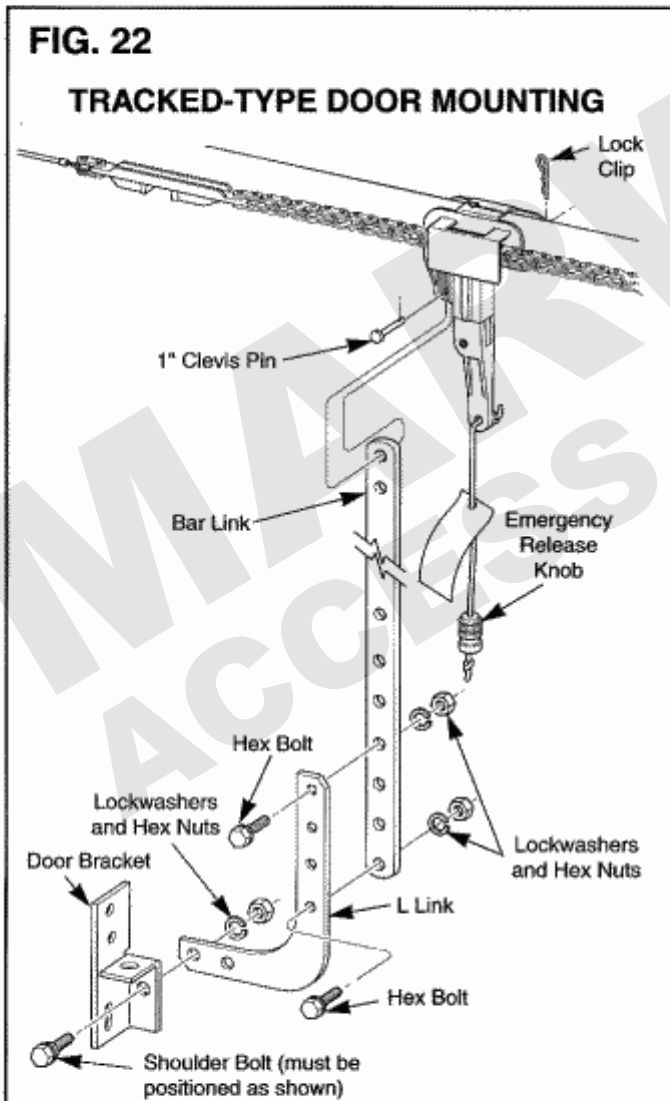
N. Once power unit is securely mounted, remove all supports and ladders. Operate door manually several times to ensure that door travels freely and does not contact tube. Top edge of door should clear tube by at least one inch.

### FASTENERS USED ON THIS PAGE:



# INSTALLATION (CONTINUED)

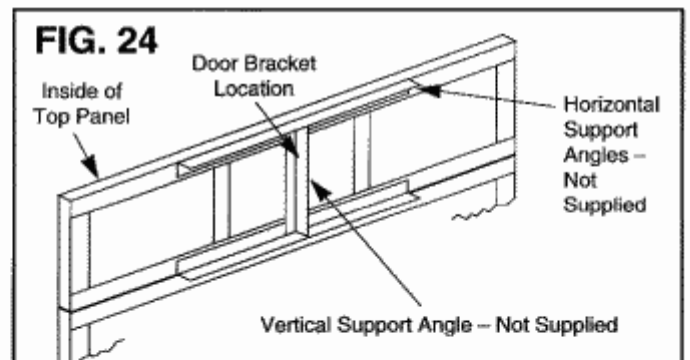
- O. Assemble L link to bar link, as shown in Fig. 22 for tracked-type doors and Fig. 23 for trackless-type doors. Use two (2) hex bolts, lockwashers and hex nuts.
- P. Attach door bracket to L link and bar link assembly. Use shoulder bolt, lockwasher and hex nut. Be sure it is assembled as shown.
- Q. Attach L link and bar link assembly to traveler by inserting the 1 inch clevis pin through traveler and assembly. Insert a lock clip through small hole in clevis pin. Assemble as shown in Fig. 22 for tracked-type doors or Fig. 23 for trackless-type doors.
- R. Pull emergency release cord and slide traveler toward door.



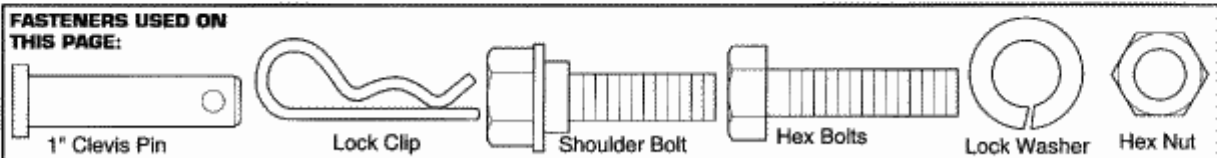
## DOOR REINFORCEMENT

**IMPORTANT NOTICE:** TO PREVENT POSSIBLE DAMAGE TO GARAGE DOORS, LIGHTWEIGHT STEEL AND FIBERGLASS DOORS **MUST BE REINFORCED** BEFORE DOOR BRACKET IS INSTALLED. ALWAYS SUPPORT INSIDE OF DOOR BOTH VERTICALLY AND HORIZONTALLY WITH A 2"x4" BOARD, CHANNEL, OR ANGLE IRON. VERTICAL BRACE MUST COVER AT LEAST THE TOP PANEL OF A SECTIONAL DOOR, AND HORIZONTAL BRACE MUST BE AT LEAST SIX (6) FEET LONG. SEE FIG. 24.

**FAILURE TO PROPERLY BRACE DOOR PRIOR TO INSTALLATION OF OPENER MAY RESULT IN SEVERE DOOR DAMAGE. ADDITION OF BRACES MAY AFFECT BALANCE OF DOOR. AFTER INSTALLATION, CHECK FOR PROPER MANUAL OPERATION AND CONTACT A CERTIFIED SERVICE PERSON TO REBALANCE DOOR IF NECESSARY.**



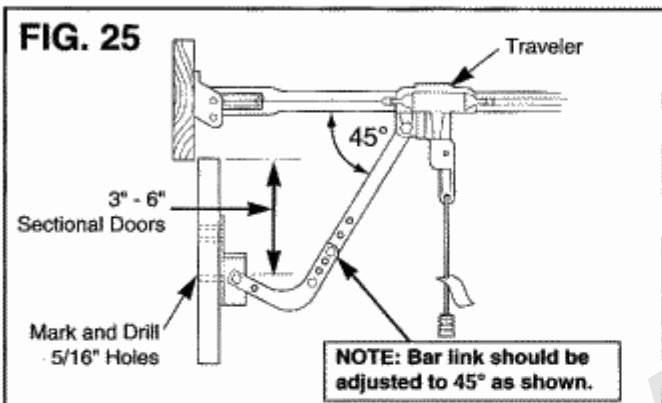
### FASTENERS USED ON THIS PAGE:



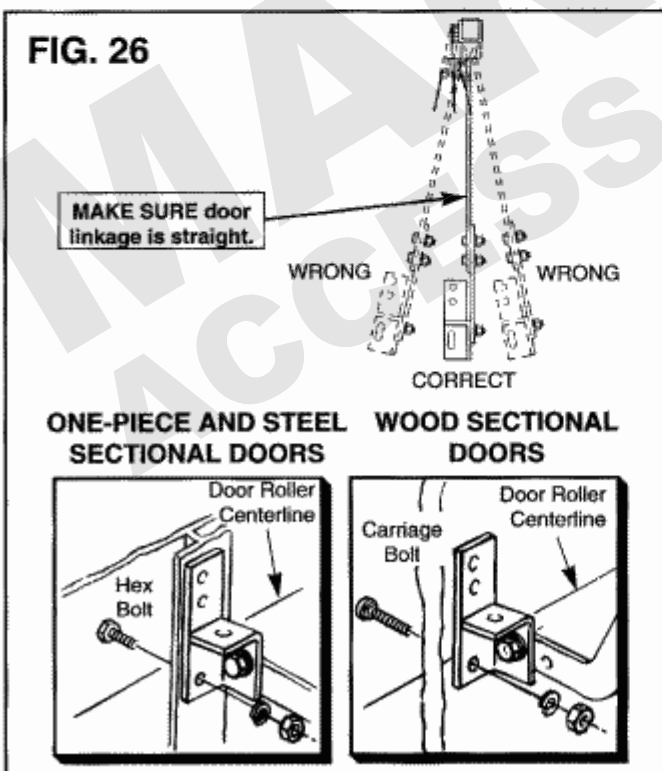
# INSTALLATION (CONTINUED)

S. Position door bracket near top of door, as close as possible to center of top door roller. Mark two holes on door. On sectional doors, door rollers should be 3" to 6" from top of door. If not, simply position bracket 3" to 6" below top of door. Bar Link should be adjusted to 45°. See Fig. 25.

T. Slide traveler back and drill two (2) 5/16" holes through door at marked holes.



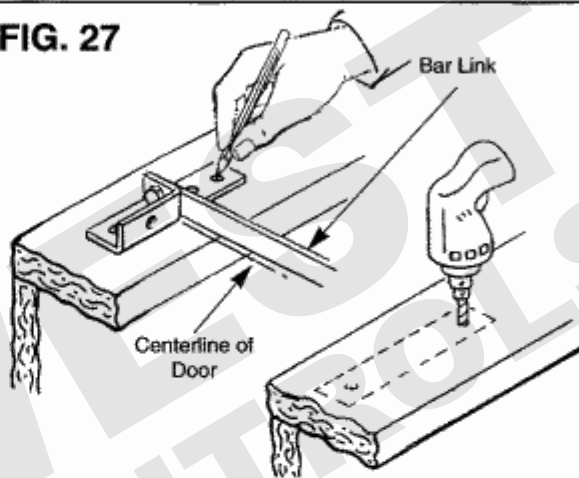
U. Move traveler assembly toward door and attach bracket to door. Use hex bolts or carriage bolts to fasten bracket to door. See Fig. 26.



## SPECIAL INSTRUCTIONS! TRACKLESS DOORS ONLY

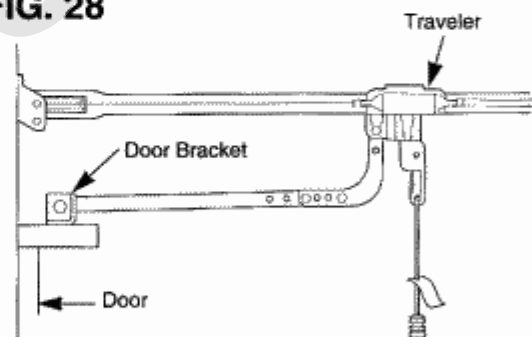
Position door bracket on top edge of door, directly on centerline. Use a pencil to mark hole locations on door. Drill (2) 5/16" holes through door at marked holes. See Fig. 27.

**FIG. 27**



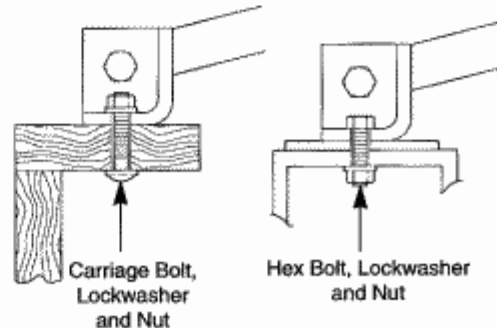
Use hex bolts or carriage bolts to fasten bracket to door. See Fig. 28.

**FIG. 28**

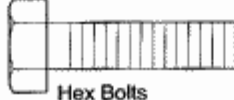


**WOOD DOORS**

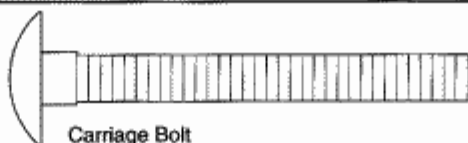
**METAL DOORS**



**FASTENERS USED ON THIS PAGE:**



OR



# BEAM SENSOR MOUNTING



**IMPORTANT: DOOR OPENER WILL NOT OPERATE UNTIL BEAM SENSOR IS CONNECTED TO POWER UNIT AND PROPERLY ALIGNED. RED ALIGNMENT LIGHT MUST BE ON. OTHERWISE, DOOR CAN BE CLOSED BY MAINTAINING CONSTANT PRESSURE ON WALL-MOUNTED PUSHBUTTON ONLY.**

- A. Use four thumb screws to attach sending and receiving units to mounting brackets. See Fig. 29.
- B. Use wood screws to attach receiving unit to wall with "Eye" 5 inches above floor. Make sure beam clears door tracks.

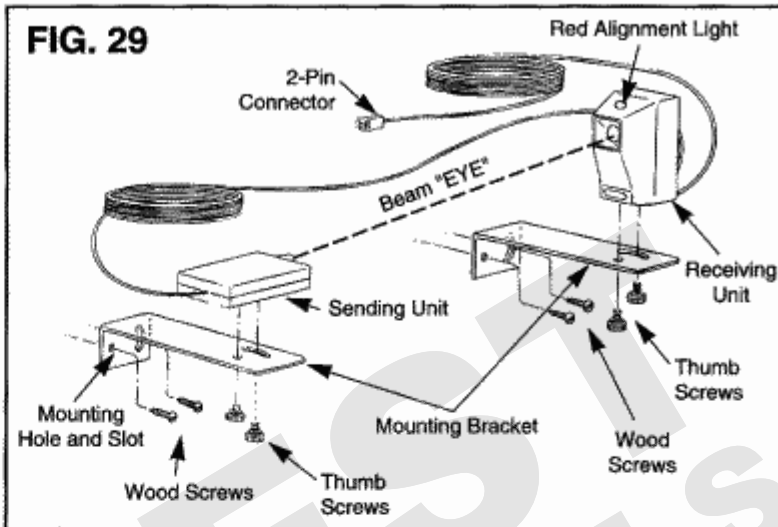
**Beam "Eye" must be mounted as close to the bottom edge of door as possible to offer maximum entrapment protection. See Fig. 30.**

- C. Run wires up wall across top of door opening, then down other side. Temporarily staple wires in place using insulated staples.



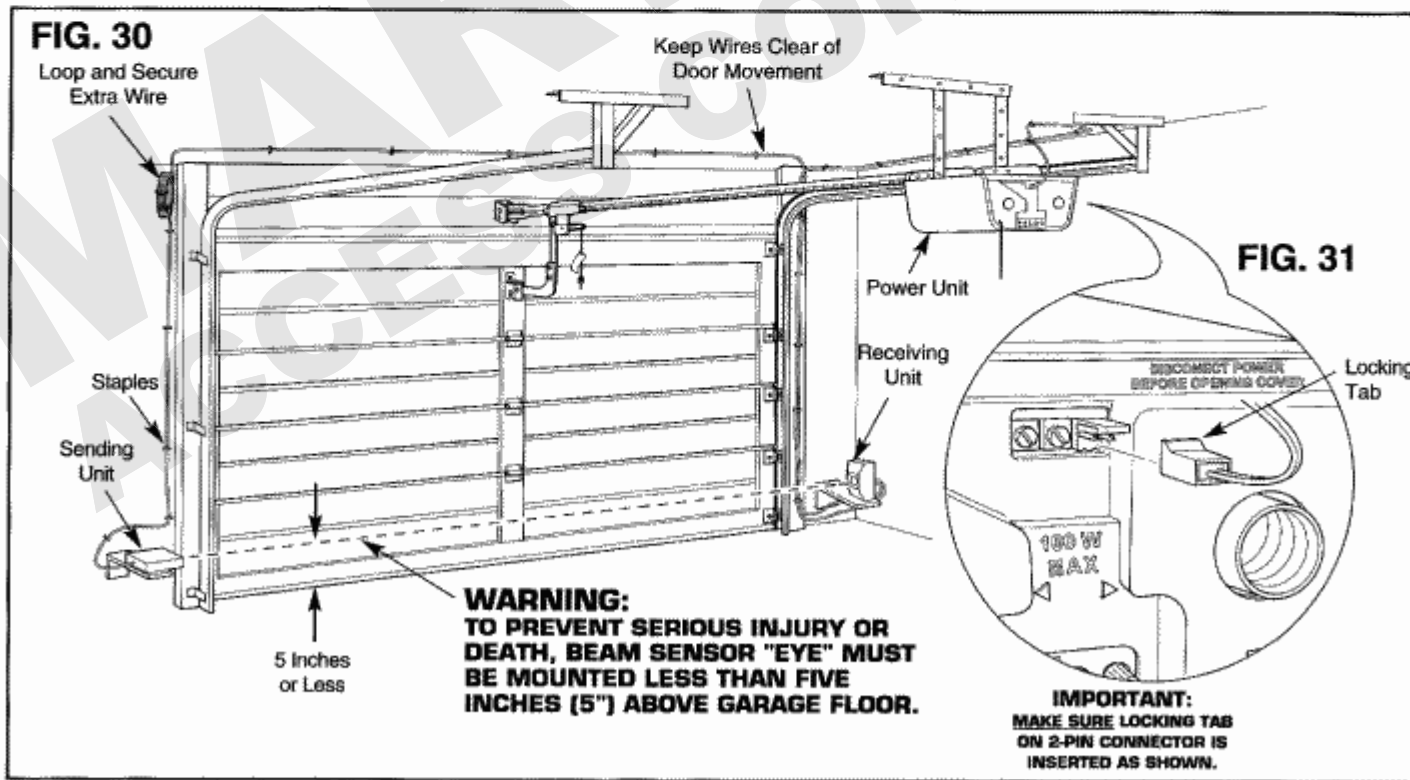
**DO NOT RUN WIRES IN A LOCATION WHERE THEY WILL INTERFERE WITH MOVEMENT OF THE DOOR.**

**FIG. 29**

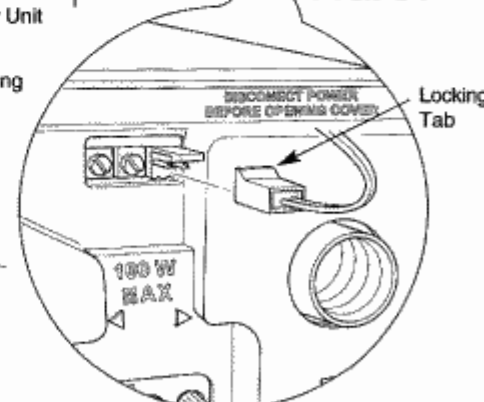


- D. Mount sending unit like receiving unit with "Eye" 5 inches or less above floor. Make sure beam clears door tracks.
- E. Uncoil remaining wire with 2-pin connector. Route wire up garage wall across ceiling to back of power unit. Secure wires in place using insulated staples.
- F. Plug beam sensor into connector at rear of power unit. **Make sure locking tab is properly inserted as shown in Fig. 31.**

**FIG. 30**

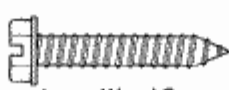


**FIG. 31**



**IMPORTANT: MAKE SURE LOCKING TAB ON 2-PIN CONNECTOR IS INSERTED AS SHOWN.**

**FASTENERS USED ON THIS PAGE:**



Large Wood Screws



Thumb Screws



Staples

# PUSHBUTTON INSTALLATION

- A. Strip 1/4" of insulation off each end of pushbutton wire. Connect wires to two screws on rear of pushbutton as shown in Fig. 32.
- B. Mount pushbutton out of the reach of children (**at least 5 feet above the floor**) with wood screws. See Fig. 35.
- C. Using insulated staples, run wire from pushbutton to power unit. **DO NOT STAPLE THOUGH WIRES**, or place wire close to 120 volt power wires. Separate as far as possible. **NOTE:** If garage has more than one opener, keep pushbutton wires separated as far as possible.

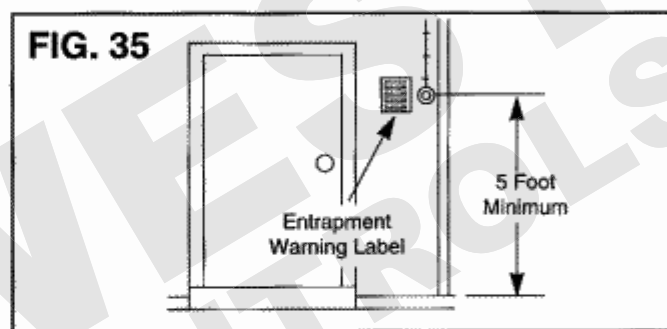
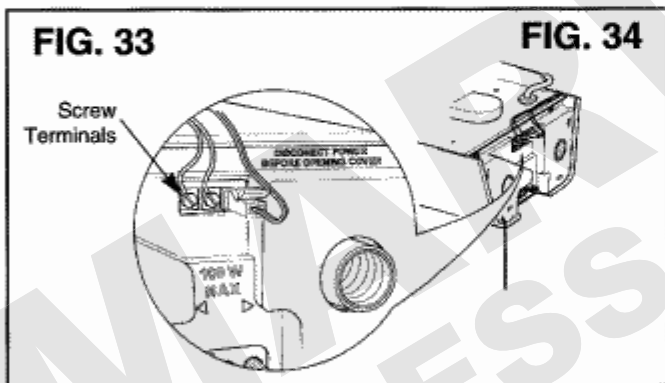
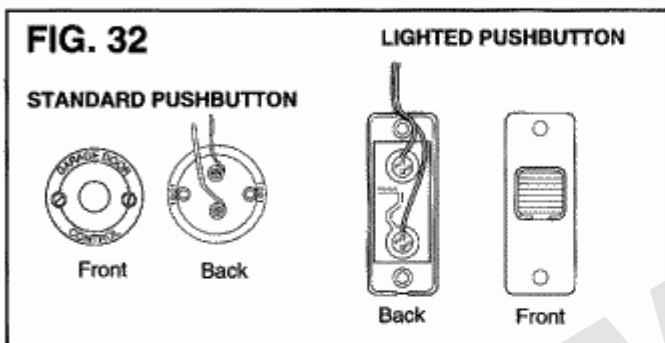
- D. Strip about 1/4" of insulation off other end of wire and connect to screw terminals at rear of power unit. See Figs. 33 and 34.
- E. Mount **Entrapment Warning Label** near pushbutton. Secure label with staples, if necessary. See Fig. 35.



**IMPORTANT: MOUNT PUSHBUTTON HIGHER THAN A CHILD CAN REACH AND IN A LOCATION WHERE DOOR IS EASILY VISIBLE.**



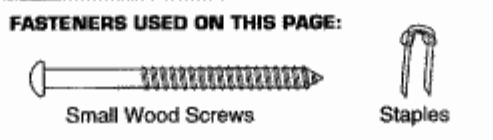
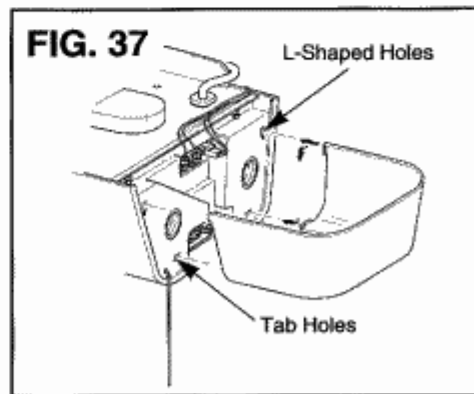
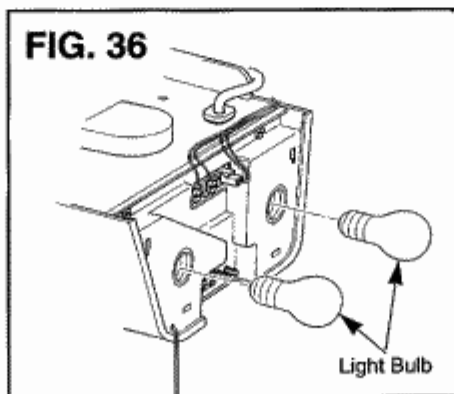
**NEVER PASS UNDER A MOVING GARAGE DOOR.**



**NOTE:** (For lighted pushbuttons and four-function wall console only.) If pushbutton does not light after power is applied to the opener on the next page, reverse the two wires connected to the screw terminals on rear of power unit.

# LIGHTING

- A. Install light bulbs into lamp sockets.  
**NOTE:** Do **NOT** use light bulbs rated more than 100 watts each. "Rough service" bulbs are suggested. See Fig. 36.
- B. Lights stay on for 4-1/2 minutes when door opens or closes.
- C. Insert top tabs of light cover into L-shaped holes in panel. See Fig. 37.
- D. Slide light cover down, then snap bottom tabs of cover into tab holes in panel.





# IMPORTANT SAFETY INSTRUCTIONS



**WARNING:** BEFORE CONNECTING POWER, PLEASE REVIEW THESE IMPORTANT SAFETY INSTRUCTIONS. THEY ARE DESIGNED TO REDUCE THE RISK OF SEVERE INJURY OR DEATH. READ AND FOLLOW ALL INSTRUCTIONS CAREFULLY.

- A. NEVER LET CHILDREN OPERATE, OR PLAY WITH DOOR CONTROLS. KEEP REMOTE CONTROL AWAY FROM CHILDREN.
- B. ALWAYS KEEP MOVING DOOR IN SIGHT AND AWAY FROM PEOPLE AND OBJECTS UNTIL IT IS COMPLETELY CLOSED. NO ONE SHOULD CROSS THE PATH OF THE MOVING DOOR.
- C. TEST DOOR OPENER MONTHLY. THE GARAGE DOOR MUST REVERSE ON CONTACT WITH A 1-1/2 INCH OBJECT (OR A 2" X 4" BOARD LAID FLAT) ON THE FLOOR. IF ADJUSTING EITHER THE DOOR FORCE OR DOOR POSITION, RETEST THE

DOOR OPENER. FAILURE TO ADJUST THE OPENER PROPERLY MAY CAUSE SEVERE INJURY OR DEATH. CONDUCT ALL SAFETY REVERSE TESTS AT LEAST TWICE.

- D. IF POSSIBLE, USE THE EMERGENCY RELEASE ONLY WHEN THE DOOR IS CLOSED. USE CAUTION WHEN USING THIS RELEASE WITH THE DOOR OPEN. WEAK OR BROKEN SPRINGS MAY CAUSE THE DOOR TO FALL RAPIDLY, CAUSING INJURY OR DEATH.
- E. KEEP GARAGE DOORS PROPERLY BALANCED. SEE OWNERS MANUAL. AN IMPROPERLY BALANCED DOOR COULD CAUSE SEVERE INJURY. HAVE A QUALIFIED SERVICE PERSON MAKE REPAIRS TO CABLES, SPRING ASSEMBLIES AND OTHER HARDWARE.
- F. SAVE THESE INSTRUCTIONS.

## POWER CONNECTION

PLUG OPENER CORD INTO OUTLET. TO REDUCE THE RISK OF ELECTRIC SHOCK, CONNECT POWER CORD ONLY TO A PROPERLY GROUNDED 3 PRONG 120 VOLT OUTLET. DO NOT USE AN EXTENSION CORD OR CHANGE PLUG IN ANY WAY. IF PLUG DOES NOT FIT INTO OUTLET, CONTACT A QUALIFIED ELECTRICIAN TO INSTALL A PROPER OUTLET.



**IMPORTANT:** DOOR OPENER WILL NOT OPERATE CORRECTLY FROM REMOTE CONTROL AND WALL-MOUNTED PUSHBUTTON UNTIL:

1. Garage door is properly balanced. (See Page 2.)
2. Beam sensor is installed and properly aligned.
3. Door force and door position adjustments are properly set.

## PERMANENT WIRING INSTRUCTIONS



**DISCONNECT POWER AT FUSE BOX BEFORE PROCEEDING.**

**NOTE:** Where required by local codes, opener must be permanently wired by a licensed electrician.

- A. Cut off power cord about three inches from outside of frame.
- B. Loosen four corner screws and remove cover.
- C. Remove black plastic strain relief bushing, then remove the remaining power cord covering. Pull loose wires into power unit.
- D. Using appropriate sized wire nuts, attach incoming white "neutral" wire to white wire, black "hot" wire to the black wire, and green "ground" wire to the green wire inside the power unit.
- E. Replace cover and switch power ON at fuse box.

## BEAM SENSOR ALIGNMENT

- A. Beam sensor will "Beep" if not properly aligned or is obstructed. Align beam sensor by moving sending and receiving units **up or down** and **left or right** until red alignment light on receiving unit comes on. Thumb screws on bottom can be loosened to move sensor **left or right**, and mounting screws that fasten mounting brackets to wall can be loosened to move sensor **up or down**. See Fig. 38.
- B. Pivot sensors **up or down** and **left or right** until you find the center of the operation. Tighten all thumb screws and mounting screws when system is centered.
- C. Finish securing all wire, making sure not to break or short any of the wires. Loop and secure any extra wire.

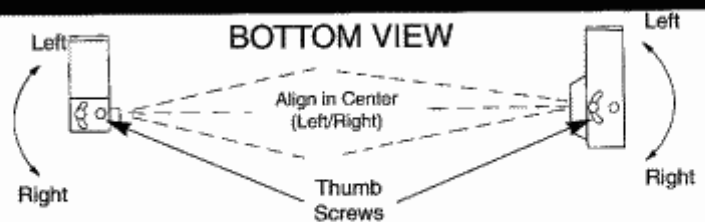
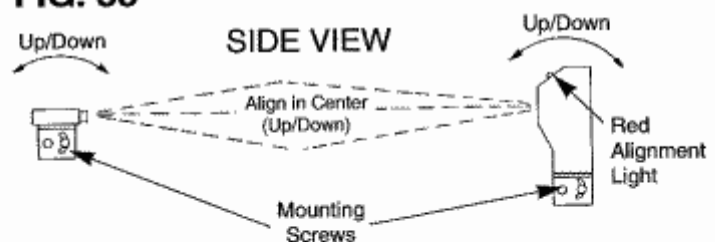


FIG. 38





# DOOR FORCE ADJUSTMENTS

- A. The **UP** and **DOWN DOOR FORCE** adjustments on rear of power unit allow you to select how much opening and closing force power unit will apply. See Fig. 39.
- B. As a door force **STARTING POSITION ONLY**, identify door type, then use the chart below and select the door force on the two door force dials on rear of power unit.

DOOR FORCE:	DOOR CONSTRUCTION
1-3	Single car - light, steel & fiberglass
3-5	Single car - wood/Two car - steel or fiberglass
5-7*	Two car - wood
7-8*	Very large heavy doors

**IMPORTANT:** If in the next step, while adjusting the **FULL UP** and **FULL DOWN** position of door, it requires more force to move your door up or down than what you selected, the door will reverse while closing or stop while opening. The lights on the power unit will flash. Simply select more force and operate door again.

**\*CAUTION:** IF YOU SELECT TOO MUCH DOOR FORCE, OR DID NOT PROPERLY REINFORCE YOUR DOOR (IF REQUIRED) AS INSTRUCTED, YOU MAY SEVERELY DAMAGE YOUR GARAGE DOOR AND DOOR OPENER. **ALWAYS** SELECT THE LOWEST FORCE POSSIBLE TO OPERATE YOUR DOOR.

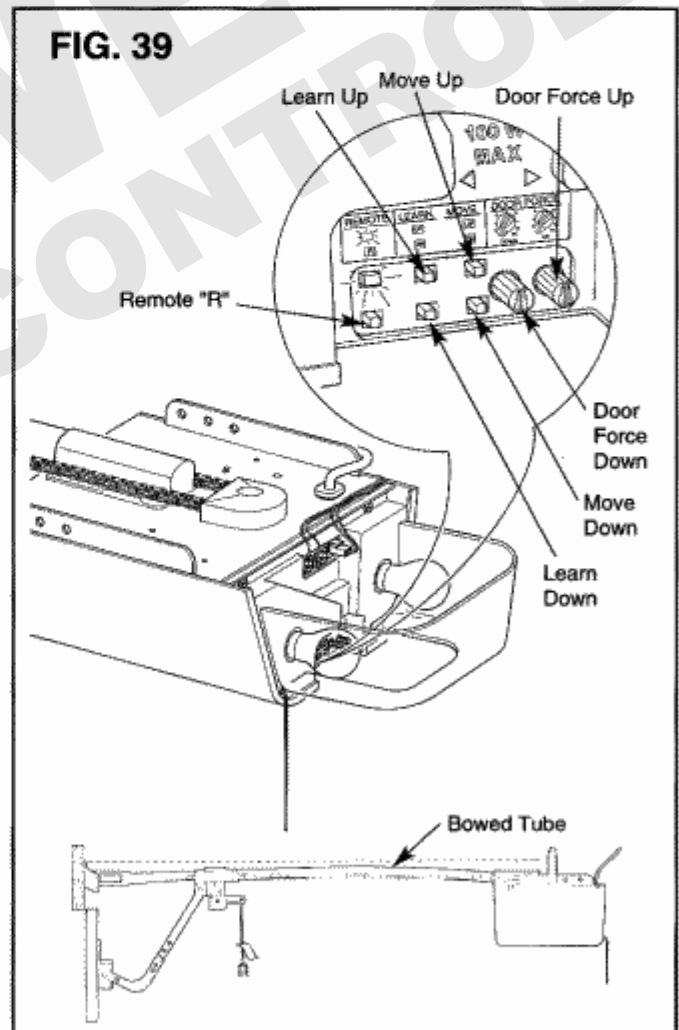
# DOOR POSITION ADJUSTMENTS

**IMPORTANT:** The **FULL UP** position of the door **MUST** be adjusted before the **FULL DOWN** position. The door opener will become inoperative and the lights will blink rapidly if you do not follow these instructions properly.

If motor overload protector activates while making the door position adjustments, power will automatically be removed and door opener will stop. Wait at least ten minutes, then repeat steps A through E.

- A. Locate the four (4) buttons on rear of power unit labeled **LEARN UP** and **DOWN (DN)**, and **MOVE UP** and **DOWN (DN)**. These are used to adjust the **FULL UP** and **FULL DOWN** positions of the door. See Fig. 39.
- B. To set the **FULL UP** position of the door, **PRESS AND CONTINUE TO HOLD** the **LEARN UP** button, then press the **MOVE UP** button until the door is in the **FULL UP** position. See Fig. 39.
- C. Next, adjust the **FULL DOWN** door position. **PRESS AND CONTINUE TO HOLD** the **LEARN DOWN** button, then press the **MOVE DOWN** button until the door is in the **FULL DOWN** position and secure against the floor. The door opener tube should be slightly bowed. See Fig. 39.
- D. Use the wall mounted pushbutton to **FULLY OPEN** then **FULLY CLOSE** the garage door.
- E. During the first **CLOSE** cycle, the door will close with more force and the tube will bow slightly more than you selected. This indicates the door opener is "finding" the floor. All future cycles will be as you selected.

**NOTE:** If the door reverses while closing or stops while opening as you are setting the door position adjustments, you may need to select a higher door **UP** or **DOWN** force. See door force adjustment section above. You must also make sure beam sensor alignment light is **ON**.



# REMOTE CONTROL PROGRAMMING

**WARNING:** KEEP REMOTE CONTROLS OUT OF THE REACH OF CHILDREN AT ALL TIMES. DOOR MAY OPERATE DURING THE NEXT STEPS. KEEP DOOR PATHWAY CLEAR.

**NOTE:** Remote control will NOT operate door opener until you set DOOR POSITION ADJUSTMENTS.

- Press the REMOTE "R" button under red light on rear of power unit. Red light above button and lights on power unit will come on. See Fig. 40.
- While lights are still on, press button on remote control you wish to use to operate door. Lights will blink two times then turn off. See Fig. 41.
- Press this SAME button on remote control again to activate door opener.
- To program additional remote controls, repeat steps A through C.
- If you wait 30 seconds, the lights will turn off allowing you to start over.
- If you HOLD the REMOTE "R" button for 10 seconds, the lights will blink 6 times. ALL remote control programming will be erased, allowing you to start over. See Fig. 42.

## EXTRA REMOTE CONTROL BUTTONS

(For remote controls with more than one button)

The second and third buttons on your remote control can be programmed to control additional Stanley Secure Code door openers or the lights on your power unit. Simply repeat the programming sequence shown above for each button.

## LIGHT CONTROL

If you program a second button on the SAME remote control to the SAME opener, the button can be used to turn the power unit lights ON and OFF.

## BATTERY REPLACEMENT

Your remote control contains two (2) size 2016 batteries which can be replaced by removing the screw on the bottom of the case. Carefully watch how the unit comes apart (battery +) so that you can properly put it back together.

### FCC Radio Usage Limitations

**CAUTION:** The garage door operator and all accessory radio equipment have been designed to Federal Communications Standards for Part 15 radio devices. Operation of this device is subject to the following conditions: (1) This device may not cause harmful interference; (2) This device must accept any interference that may be received, including interference that may cause undesired operation; (3) Changes or modifications not expressly approved by the manufacturer could void the authority of users to operate this equipment.

FIG. 40

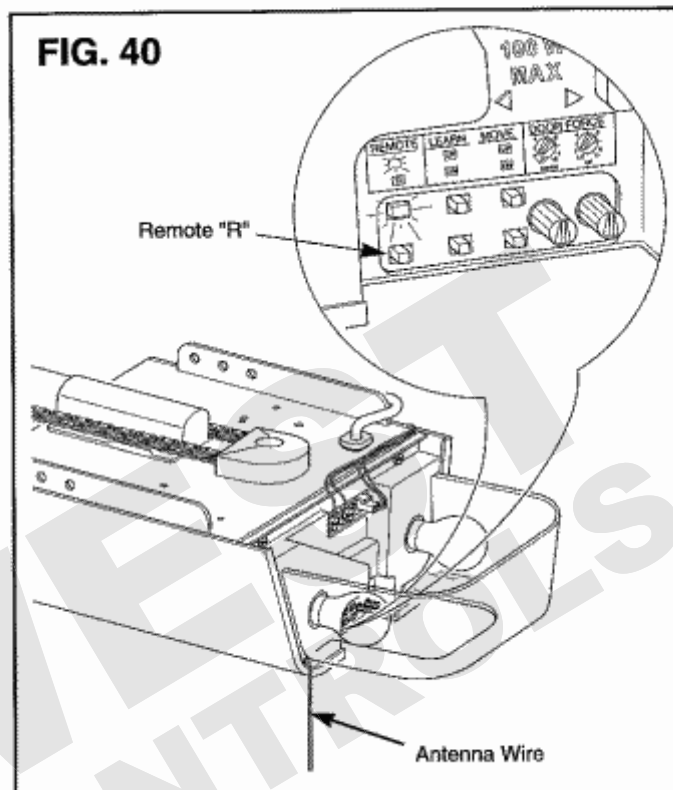


FIG. 41

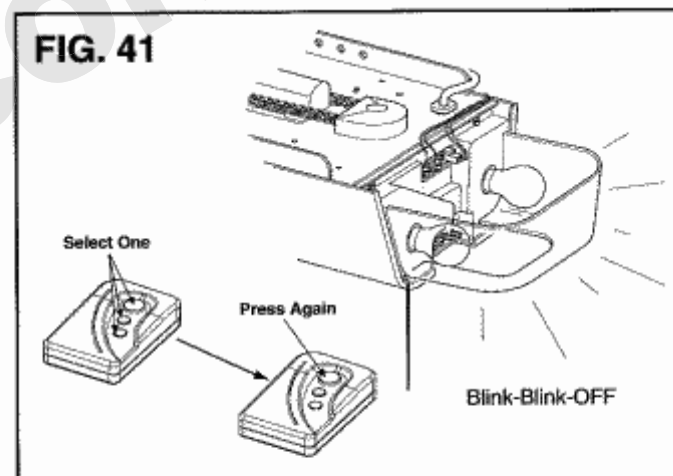
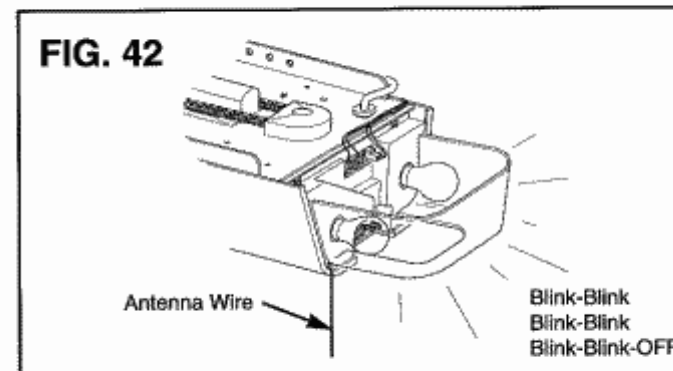


FIG. 42



# SAFETY REVERSE SYSTEM TESTING



**WARNING: SEVERE DAMAGE TO DOOR, DOOR OPENER OR PERSONS MAY OCCUR IF THE UP OR DOWN FORCE IS SET TOO HIGH FOR CONDUCTING THE FOLLOWING TESTS. KEEP DOOR PATHWAY CLEAR.**

## OBSTRUCTION TESTING:

- While the door is going down, extend your hands under the bottom edge of the door (use gloves). The door should **EASILY** reverse off of your hands and begin to go up. If it does not, select a **LOWER** down force, and test again. See Fig. 43.
- While the door is opening, grasp the bottom edge and try stopping it. Do not put your fingers between door sections. The door should **STOP**, with minimum force applied. If it does not, select a **LOWER** up force, and test again.

**IMPORTANT:** This test must be conducted two times in a row to test the door force you selected.

## ENTRAPMENT TESTING:

- Place a 1-1/2 inch object (or a 2" x 4" laid flat) under the center of the door opening, then activate the door to close. Make sure door linkage is adjusted correctly. The door should contact the object, then reverse and open. If it does not, reset up and down door positions, select a lower **DOWN FORCE** and test again. (See page 17). See Fig. 44.
- If selecting a lower down force does not correct the problem, you **MUST** go back to the **DOOR POSITION** adjustment section. First, readjust the full up position of the door, then readjust the full down position to be much more secure against the floor. Test again and readjust if necessary.
- Repeat this procedure until the door reverses off of the 1-1/2 inch high object. Make sure door linkage is properly adjusted. (See page 13.)

**IMPORTANT:** This test must be conducted two times in a row to ensure proper entrapment protection.

## BEAM SENSOR TESTING

- While the door is closing, place an object in front of the beam sensor eye. See Fig. 45. The sensor should "beep" and the door should reverse and open.
- Blocking the sensor while the door is opening will have no affect on the door operation. Sensor will "beep" only.

FIG. 43

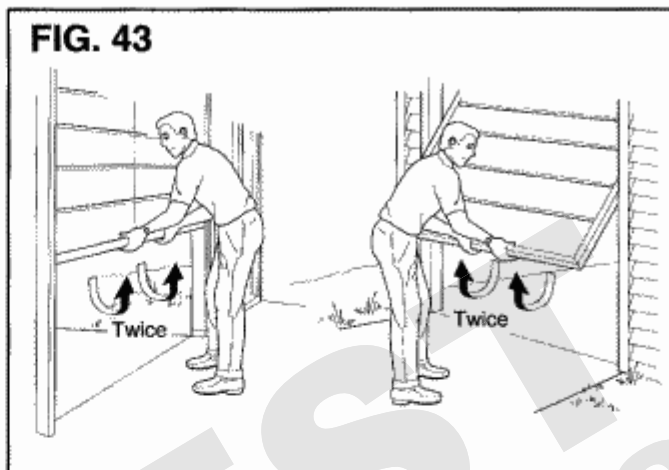


FIG. 44

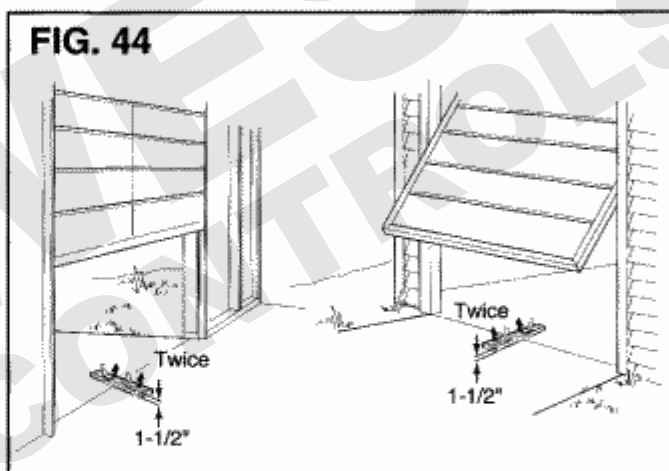
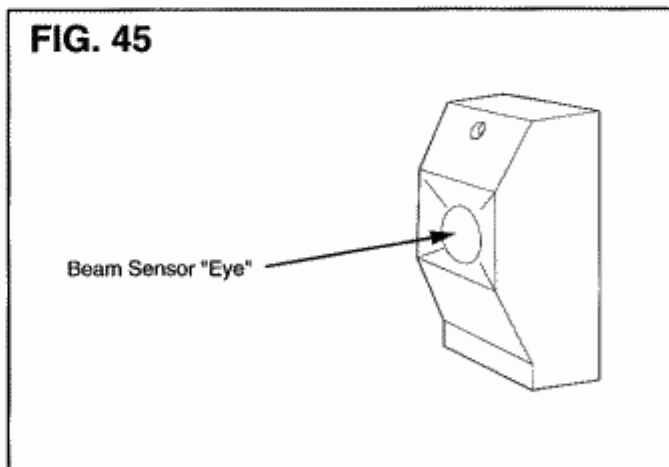


FIG. 45



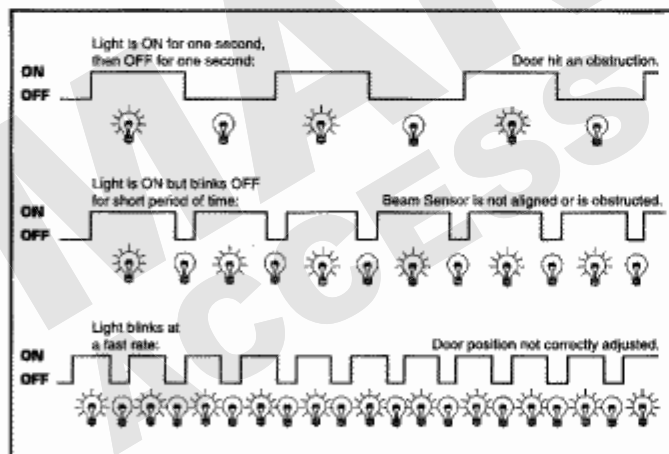
# TROUBLESHOOTING: PROBLEM/SOLUTION

## OPENER DOES NOT WORK

- A. Make sure there is power at the 120 volt outlet where opener is plugged in.
- B. The motor overload protector may be activated. Wait 10 minutes for the motor to cool.
- C. Remote control will not close door until beam sensor is attached and aligned.
- D. If a four-function wall console is being used, make sure the vacation switch is in the "UNLOCKED" position.
- E. Pull the emergency disconnect cord to release the door from the opener. Check to see if the opener will operate if not connected to the door. If opener now operates, review "Door Balance Test" in the front of manual.
- F. Remove the pushbutton wires and try remote control.

## LIGHTS FLASHING - SMARTFLASH™

- A. If it requires more force to move the door than you selected with the open or close force adjustments, lights on the opener will blink. An obstruction or poorly operating door may be the cause. Review "Door Balance Test" and "Open and Close Force Adjustments."
- B. If the beam sensor is obstructed or not aligned, the lights on the opener will blink as shown below. The door can only be closed by holding the wall-mounted pushbutton.



## REMOTE CONTROL DOES NOT WORK OR HAS SHORT RANGE

- A. Review the "Remote Control Programming" section in manual.
- B. Replace battery in remote control with one of the same type.
- C. Try moving or coiling the antenna wire on opener.

## PUSHBUTTON DOES NOT WORK

- A. Make sure the pushbutton wires are not broken or shorted.
- B. Disconnect wires from back of opener and "short" across the two screw terminals using a screwdriver. If opener operates, the pushbutton wires are shorted or broken.

## DOOR CLOSSES - THEN OPENS

- A. Is something obstructing the door? Remove obstruction, then operate door again.
- B. Climatic conditions may heave or sink garage floor. Review the "Door Position Adjustments" and "Entrapment Test" instructions.

## EXCESSIVE TUBE BOW

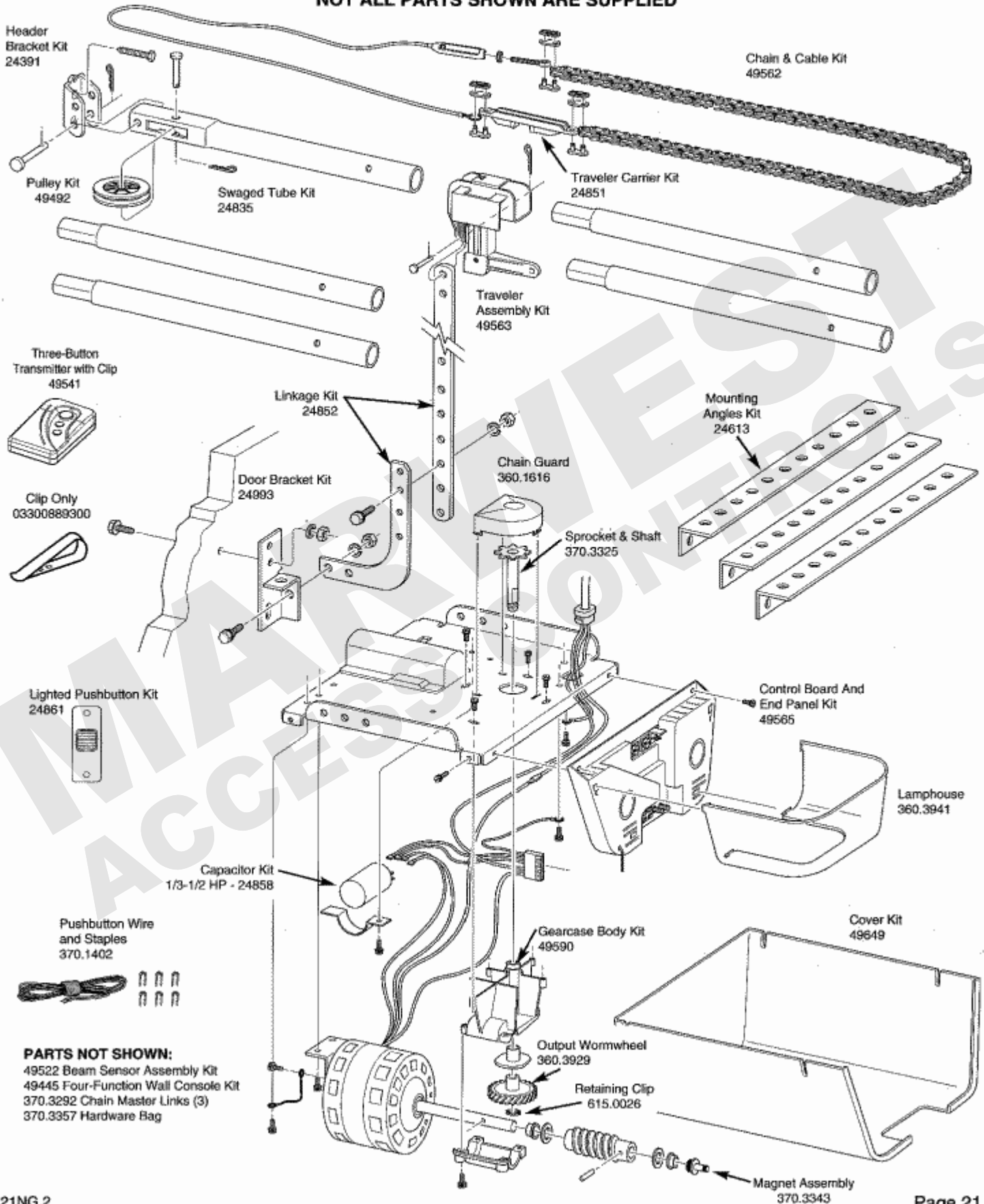
- A. Make sure power unit is securely mounted and door operates freely. Review "Door Balance Tests." Is something obstructing the door?
- B. Review "Door Position Adjustment" and "Entrapment Test."

## LIGHT STAYS ON

- A. The lighting feature turns opener lights on for 4-1/2 minutes after opener has been activated.
- B. **Worklight** switch (supplied only with four-function wall console) may be "ON."
- C. **Pedestrian** light switch (supplied only with four-function wall console) turns lights on for 4-1/2 minutes.

# Parts List

NOT ALL PARTS SHOWN ARE SUPPLIED



## PERIODIC INSPECTIONS (CHECK THESE ITEMS MONTHLY)

**SAFETY:** The **ENTRAPMENT TEST** is the single most important step in the installation of your garage door opener. The door must reverse when it comes in contact with a one and one half inch (1-1/2") high solid object placed on the garage floor. If door does not reverse, refer to **Entrapment Test Instructions** in this manual or contact a door system professional.



Failure to comply with this requirement may result in serious or fatal injury to anyone trapped by a closing garage door.

**CAUTION:** DISCONTINUE USAGE AND CONTACT AN AUTHORIZED DEALER OR THE CUSTOMER SERVICE DEPARTMENT ANY TIME A MALFUNCTION IS OBSERVED.

**LUBRICATION:** Lubricate all moving parts of door with light oil several times yearly, including roller shafts. Do not lubricate tracks or surfaces of nylon rollers.

**DOOR BALANCE TEST:** Check door balance at 3/4 open, mid-point and 3/4 closed positions. Refer to "Door Balance Test" in this manual.

**EMERGENCY RELEASE:** Close garage door and pull red emergency release knob to ensure that door can be released from opener.

**HARDWARE:** Inspect chain/cable tension and retighten all nuts and bolts.

## IN-WARRANTY HELP LINE

Prior to calling the number below, review "Troubleshooting" on page 20 and "Parts List" on page 21.

During warranty period, if product becomes inoperative, call our Toll Free service before removal of unit. A technician will diagnose the problem and promptly supply you with the parts for DO-IT-YOURSELF replacement.

For technical questions or to place orders by phone, please call us at (800)849-3998 Mon-Fri 9am-5pm & Saturdays 9am-1pm Pacific Time, international calls use (818)725-7125



## AFTER WARRANTY HELP LINE

Your local dealer stocks parts and accessories.

See your yellow pages listing under the following headings:

- Door Operating Devices
- Garage Doors and/or Garages
- Garage Door Openers

If you are unable to locate a local source for service or parts, call us at 1-800-850-5967. A charge will result.

# WARRANTY INFORMATION

Your Innovative Home Products garage door opener and remote radio controls are warranted against deficiencies in material and workmanship for a specific period of time based on which model number you have, providing recommended installation and maintenance procedures are followed.

THIS WARRANTY IS IN LIEU OF ALL OTHER WARRANTIES, EXPRESSED OR IMPLIED (SOME STATES DO NOT ALLOW LIMITATIONS ON HOW LONG AN IMPLIED WARRANTY LASTS, SO THIS LIMITATION MAY NOT APPLY TO YOU) AND SHALL BE CONSIDERED VOID IF DAMAGE WAS DUE TO IMPROPER INSTALLATION OR USE, CONNECTION OF IMPROPER POWER SOURCE, OR IF DAMAGE WAS CAUSED BY FIRE OR LIGHTNING.

The Manufacturer will not be responsible for any labor charges incurred in the removal or replacement of deficient parts. In case of failure due to deficient material or workmanship during the warranty period, the electronic components (control board and transmitters) or the complete garage door opener will be repaired or replaced at the Manufacturer's option at no charge. For information on this warranty, you may call, toll-free 1-800-850-5967. New or factory rebuilt replacements will be used. Replacement parts are warranted for the remaining portion of the original warranty period. In the event the warranty registration is not returned, the warranty period above dates from date of shipment from Manufacturer rather than date of purchase. This warranty gives you specific legal rights, and you may also have other rights which vary from State to State. For use with 120 volt, 60 Hz current only.

## WARRANTY PERIODS

**MODEL - ST105:** Garage Door Opener and remote radio controls are warranted for a period of one (1) year from date of purchase. The motor is warranted for five (5) years.

**MODEL - ST205:** Garage Door Opener and remote radio controls are warranted for a period of one (1) year from date of purchase. The motor is warranted for seven (7) years.

**MODEL - ST305:** Garage Door Opener and remote radio controls are warranted for a period of one (1) year from date of purchase. The motor is warranted for ten (10) years.

**MODEL - ST405:** Garage Door Opener and remote radio controls are warranted for a period of one (1) year from date of purchase. The motor is warranted for ten (10) years.

**MODEL - ST505:** Garage Door Opener and remote radio controls are warranted for a period of two (2) years from date of purchase. The motor is warranted for the LIFETIME of the opener for the original purchaser in the original installation.

**MODEL - ST605:** Garage Door Opener and remote radio controls are warranted for a period of two (2) years from date of purchase. The motor is warranted for the LIFETIME of the opener for the original purchaser in the original installation.

**MODEL - SW115:** Garage Door Opener and remote radio controls are warranted for a period of one (1) year from date of purchase. The motor is warranted for five (5) years.

**MODEL - SW215:** Garage Door Opener and remote radio controls are warranted for a period of one (1) year from date of purchase. The motor is warranted for seven (7) years.

**MODEL - SW315:** Garage Door Opener and remote radio controls are warranted for a period of one (1) year from date of purchase. The motor is warranted for ten (10) years.

**MODEL - SW515:** Garage Door Opener and remote radio controls are warranted for a period of two (2) years from date of purchase. The motor is warranted for the LIFETIME of the opener for the original purchaser in the original installation.

**MODEL - SW615:** Garage Door Opener and remote radio controls are warranted for a period of two (2) years from date of purchase. The motor is warranted for the LIFETIME of the opener for the original purchaser in the original installation.

**MODEL - WH355:** Garage Door Opener and remote radio controls are warranted for a period of one (1) year from date of purchase. The motor is warranted for ten (10) years.

**MODEL - WH455:** Garage Door Opener and remote radio controls are warranted for a period of one (1) year from date of purchase. The motor is warranted for ten (10) years.

**MODEL - WH655:** Garage Door Opener and remote radio controls are warranted for a period of two (2) years from date of purchase. The motor is warranted for the LIFETIME of the opener for the original purchaser in the original installation.



**FOR YOUR RECORDS**

Date Purchased \_\_\_\_\_  
Where Purchased \_\_\_\_\_  
Model Number \_\_\_\_\_  
Date Code \_\_\_\_\_  
Date Installed \_\_\_\_\_

**DO NOT THROW THIS MANUAL AWAY!**

Keep in a Safe Place for Future Reference.

For technical questions or to place orders by phone, please call us at (800)849-3998 Mon-Fri 9am-5pm & Saturdays 9am-1pm Pacific Time, international calls use (818)725-7125

**STANLEY** **GARAGE OPENER**  
[stanley-garage-opener.com](http://stanley-garage-opener.com) **PARTS SUPER STORE**