

STANLEY

HOME AUTOMATION

THE PROFESSIONAL™

OWNER'S MANUAL

FOR USE ON MOST TYPES OF GARAGE DOORS

For technical questions or to place orders by phone, please call us at (800)849-3998 Mon-Fri 9am-5pm & Saturdays 9am-1pm Pacific Time, international calls use (818)725-7125

STANLEY

stanley-garage-opener.com

**GARAGE OPENER
PARTS SUPER STORE**

www.stanley-garage-opener.com

Installing Dealer : Please leave this owner's manual with the customer. Thank You !

GARAGE DOOR OPENERS

021.0209E
101891

HOMEOWNERS INFO & SAFETY TIPS

Dear Homeowner,

The next two pages contain **IMPORTANT** information concerning the operating features of your Stanley garage door opener as well as **SAFETY PRECAUTIONS** to be taken before, during, and after installation. Please read carefully before beginning your installation.



This caution symbol appears below and periodically throughout this manual. It will identify important safety instructions. Read these instructions carefully. Failure to follow these instructions may result in serious or fatal personal injury or costly property damage.

BEFORE BEGINNING INSTALLATION: CHECK DOOR OPERATION

LUBRICATION

Your door should move freely by hand without sticking or binding. If it does not move freely by hand, apply a light oil or silicone lubricant to the door hinges, mounting hardware, and the roller bearings. Do not apply oil or grease to the roller tracks.

DOOR TESTS

- (1) Raise your door to its midpoint and release it. Door should remain in this position, moving neither up nor down.
- (2) If the door is moved to the 3/4 open position and released, it should remain in place or move **SLOWLY** to the full open position.
- (3) If the door is moved to the 3/4 closed position and released, it should remain in place or move **SLOWLY** to the full closed position.

If the door fails any of these 3 door tests, the springs may be out of adjustment. Contact your local door dealer for assistance. Do **NOT** attempt to adjust or repair springs, cables, pulleys and mounting hardware yourself. Those parts are under **EXTREME** tension at times and can cause serious injury if improperly handled.



Do not alter or remove the door balancing springs, cables or pulleys. They are required for safe operation. If adjustment, repair or replacement is needed, contact your local door dealer for assistance or follow instructions supplied with replacement part kits. Doors with torsion springs should only be serviced by qualified servicemen.



Do not wear rings, watches or loose clothing while installing or servicing door.



Check local building and electrical codes for mandatory installation and wiring requirements.



Remove all ropes or cords attached to the garage door. Entanglement with these items may result in personal injury.



Lightweight fiberglass, aluminum, and steel doors will require reinforcement to avoid damage to door and insure proper operation of the safety reverse system.







Deactivate, or remove, all existing garage door locks. Accidental engagement of door locks may result in damage to door or opener and possibly personal injury.









Read carefully the assembly and mounting sections of this manual. It provides information on the tools, and in some cases, additional hardware required to insure a safe and speedy installation.

INFORMATION & SAFETY TIPS cont.

DURING INSTALLATION

- ★ It is recommended that the power unit be installed at least 7 ft. from the floor. This will not be possible with most one-piece doors. In this case, individuals over 6 ft. should be alert to this potential obstacle while in the garage.
 - ★ It is recommended that the red knob of the manual disconnect pull cord be adjusted to a height approximately 6 ft. from the floor. It should be reachable by all adults in the household to allow manual use of the garage door in an emergency. Place instruction tag on cord.
 - ★ If permanent wiring is required by local code, disconnect power at fuse box before attempting wiring connections.
-  For child safety, locate the pushbutton at a height where small children cannot reach it, in a location where the garage door can easily be seen.
 -  Affix the "SAFE OPERATION" caution label by the pushbutton, where it is easily visible, as a reminder of safe operating procedures.
 -  To avoid risk of electrical shock, connect the power cord to only a properly grounded outlet.
 -  The safety reverse adjustment is the single most important step in the installation of your garage door opener. The door must reverse when it comes into contact with a 1" high solid object placed on the garage floor. Failure to comply with this requirement may result in serious or fatal injury to anyone trapped by a closing garage door.

AFTER INSTALLATION

-  Never let children operate, or play with, the opener. Keep radio transmitters in the car and in an inaccessible location to children. Misuse of the opener may result in serious injury.
 -  Operate the door only when it is fully visible and clear of any obstruction. Keep the door in sight until it is completely closed. No one should pass under a moving garage door.
* KEEP CHILDREN AND PETS AWAY FROM THE DOOR WHILE IT IS MOVING!
 -  Check the safety reversing mechanism often (once a month is recommended) to insure it reverses with a minimum amount of force and will reverse off a 1" high solid object placed on the garage floor. Decreasing the safety reverse sensitivity should not be used as a means to overcome a damaged or poorly operating door. This will adversely affect the operation of the safety reverse mechanism and may damage the door or opener. PERIODICALLY CHECK THE MANUAL OPERATION OF THE DOOR.
-  Whenever possible, the manual disconnect should only be used with the door fully closed. **CAUTION** should be taken whenever the disconnect cord is pulled with the door full or partially open. Weak or broken springs may cause the door to fall rapidly, resulting in personal injury or property damage to whatever is in its path.
 -  Always disconnect electrical power to the unit if the cover needs to be removed for servicing, or when working in the area of the drive chain.
 -  If damage to any mechanical drive or structural component of the unit is observed, discontinue use and contact an authorized Stanley dealer or the Stanley Customer Service Department. Never operate the door opener if the safety system is not functioning properly.

STANLEY
helps you do things right.®

FEATURES & SPECIFICATIONS

Your new Stanley garage door opener offers momentary control. To operate the door simply press either the hand held transmitter button or the wall mounted pushbutton for one to two seconds and the door will automatically open or close. The opener can be stopped during any portion of the opening or closing cycle by pressing either of the buttons. The next actuation will re-start the door in motion in the opposite direction.

This opener has a number of safety features built into it:

SAFETY REVERSE

Should the door hit an object during the closing cycle, it will automatically reverse. The same mechanism will also stop the door if it hits an obstacle when opening. This safety system must be checked at least once a month.

SAFE-T-CYCLE™

This electronic system will reverse the door in 30 seconds or less if the door is unable to travel to the full closed position. This feature provides automatic reversing should other systems fail to operate and the door does not fully close.

SAFE-T-SIGNAL

Lights will flash whenever Safety Reverse or Safe-T-Cycle have been activated.

MANUAL DISCONNECT

Your door opener is equipped with a manual disconnect device. In the event of a power failure, pull the knob on the pull cord down and slightly to the back (away from door) allowing the disconnect to latch. This will allow you to manually open or close the door. When power has been restored, gently pull the disconnect cord, releasing the traveler detent, then press either the transmitter or pushbutton. The opener will automatically reconnect.

WORK LIGHT - FEATURE PRESENT ON SOME MODELS

This door opener is furnished with a pull chain "Work Light" that allows you to operate the lights independent of the door opener. You must remember that you can not turn off the light using the pull chain switch while the door opener Light Time Delay is working.

VACATION SWITCH - FEATURE PRESENT ON SOME MODELS

The "Vacation Switch" allows you to make the radio and pushbutton controls inactive when placed in the "Off" position. This is recommended during long periods of non-use and during lightning storms. Place switch back in the "On" position for normal use.

SPECIFICATIONS

VOLTAGE REQUIRED: 120 Volts a.c.
60 cycle
Single Phase

A grounded, three (3) hole electrical outlet is required.

MOTOR SPECS: Permanent Split Capacitor -
Internal Automatic
Overload Reset

CURRENT REQUIRED: 1/4 H.P. Models - 5 AMPS
1/3 H.P. Models - 6 AMPS
1/2 H.P. Models - 7 AMPS

OVERLOAD PROTECTION

The motor is equipped with an automatic thermal overload device. Should the motor become overheated, the overload device will render the opener inoperative. Simply wait approximately 5 to 10 minutes for the motor to cool.

OPENER LENGTH: TRACKED TYPE DOORS
10 Ft. 8 In. using a 114" Tube

TRACKLESS TYPE DOORS
8 Ft. 9 In. using an 85 1/2" Tube

MINIMUM HEAD ROOM REQUIRED: 3 1/2 In.

AVERAGE DOOR SPEED: TRACKED TYPE DOORS
7 1/2 In. Per Second

TRACKLESS TYPE DOORS
5 In. Per Second

MAXIMUM DOOR SIZE: 1/4 H.P.:
16 Ft. Wide/7 Ft. High

1/3 H.P. or 1/2 H.P.:
18 Ft. Wide/7 1/2 Ft. High

DOOR & OPENER TERMINOLOGY

This garage door opener is intended for use on one of the types of doors shown below **only**. See end of packing carton **now** before you begin assembly to insure that the door opener you have purchased can be used on your type of garage door. It is **unsafe** to attempt installation on any other type of door or moving mechanism.

Use the illustrations on this page to determine the major components of your garage door. It is suggested that before you begin with assembly, you review the mounting procedure outlined on page 12. This will help you plan out, ahead of time, a means of securing the power unit.

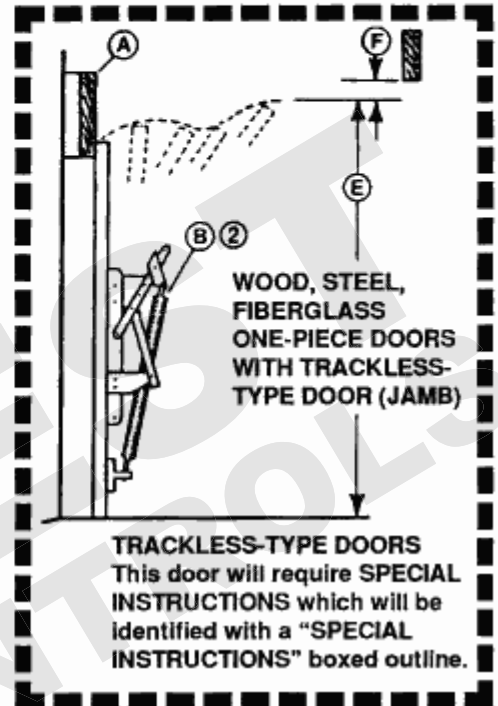
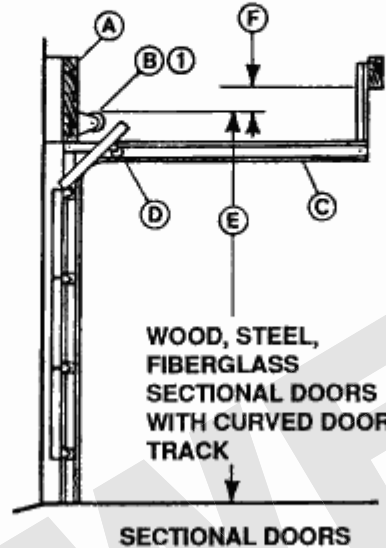
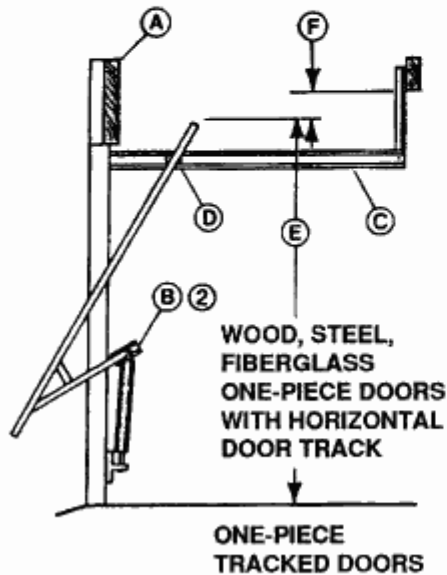

- (A) DOOR HEADER** – The wood or metal beam positioned horizontally across the top of the garage doorway.
- (B) DOOR SPRING** – Springs used to balance the door. B1 – Torsion spring, B2 - Extension spring.
- (C) DOOR TRACKS** - Metal guides to allow the door to travel a straight path. Not used on trackless doors.

- (D) DOOR ROLLERS** - Attached to the door and follow inside the door tracks. Not used on trackless doors.
- (E) HIGH-RISE** - The highest point the top of the door reaches when opening.
- (F) HEAD ROOM** - Area between high rise of door or the door spring and the bottom of rafters or finished ceilings. Do not attempt assembly with less than 3 1/2 inches of head room.

To become more familiar with your new **STANLEY DOOR OPENER**, please take time to study the following illustration of the completed unit and terminology. It will help you in the assembly and installation.

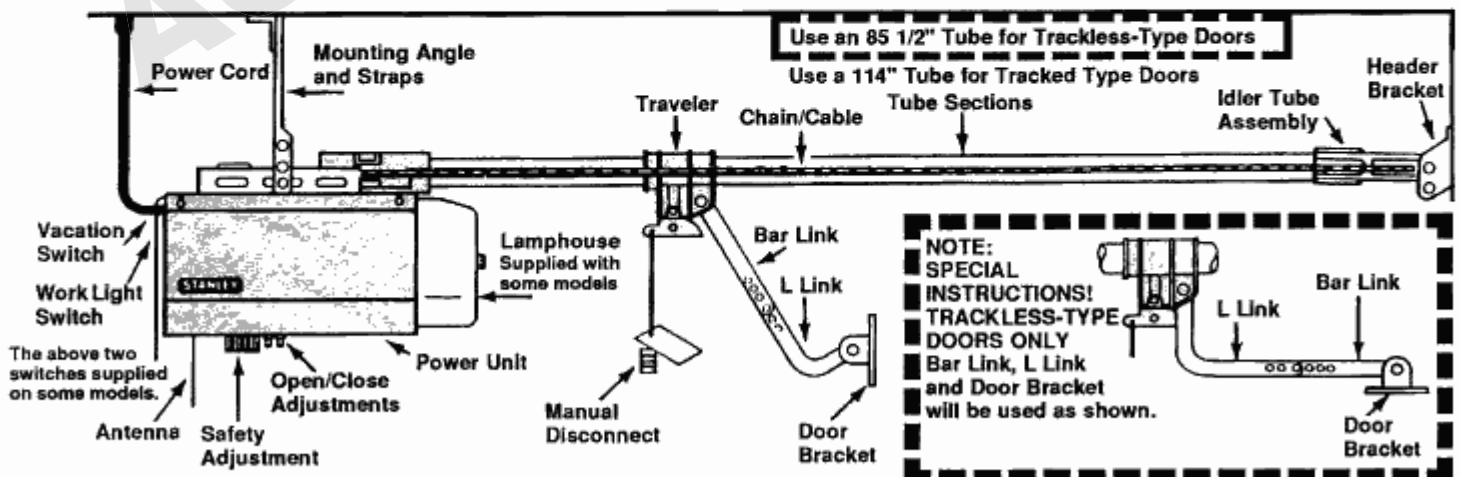

COMPONENTS & TOOLS

Carefully inspect your new garage door opener for any possible damage and/or shortage of parts. Separate all parts, fasteners and accessories as called out below.

DO NOT RUN OPENER UNTIL INSTRUCTED.
SEQUENCE OF OPERATION MAY CHANGE AND CAUSE FAULTY OPERATION!

MAJOR COMPONENTS

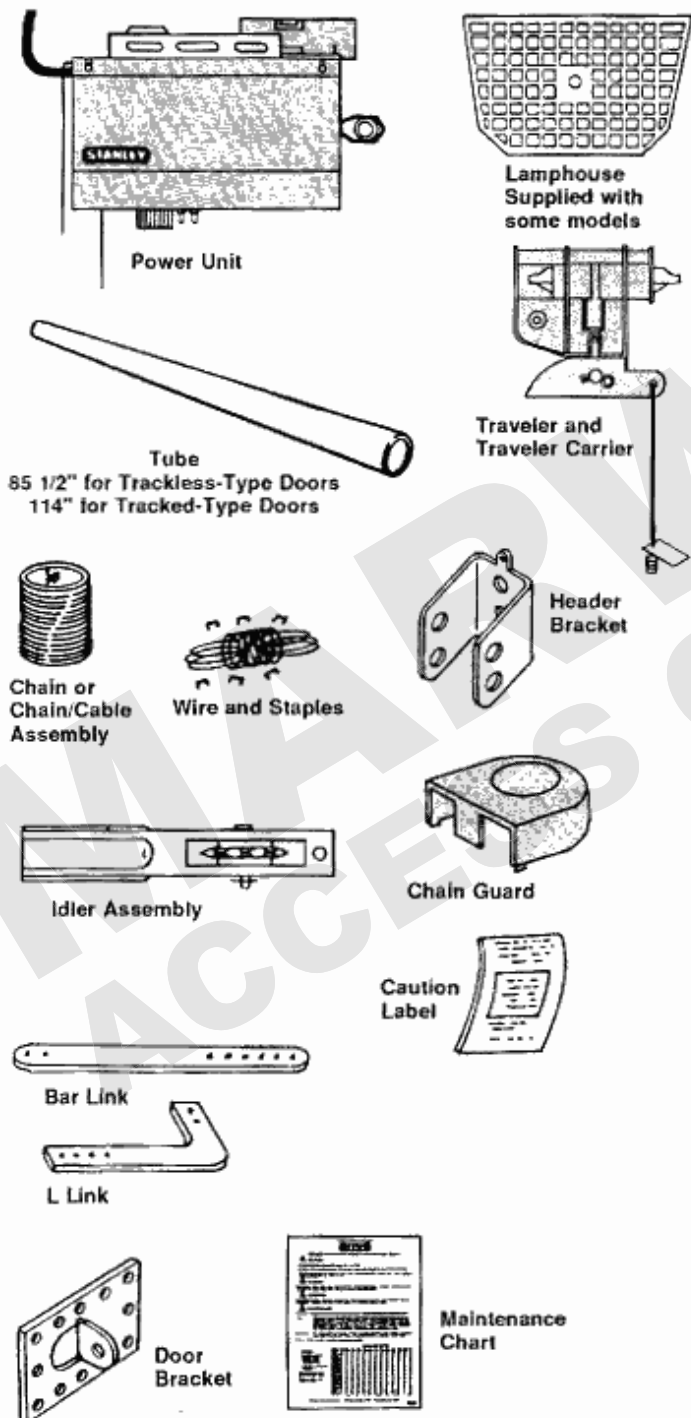

ACCESSORIES



FASTENERS

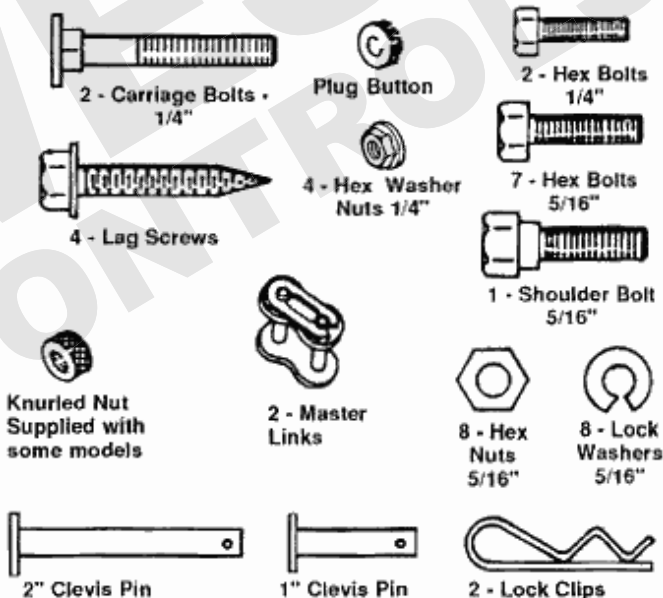

TOOLS REQUIRED

Pencil or Pen - Drill with 1/4" Drill Bit - Cross Recessed and Blade Screwdriver - Tape Measure - 7/16" and 1/2" Socket Wrenches / Adjustable Wrench - Pliers - Piece of 2" x 4" Board - Step Ladder - 1" Thick Solid Object

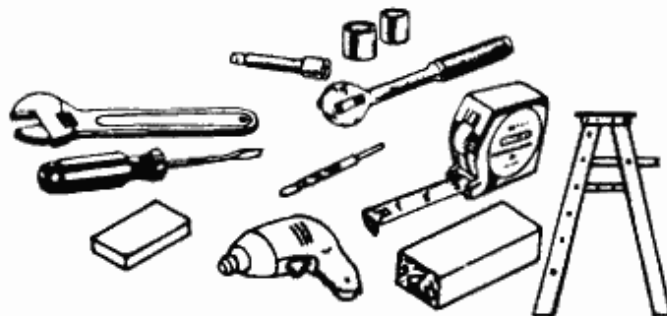

1 / ASSEMBLY

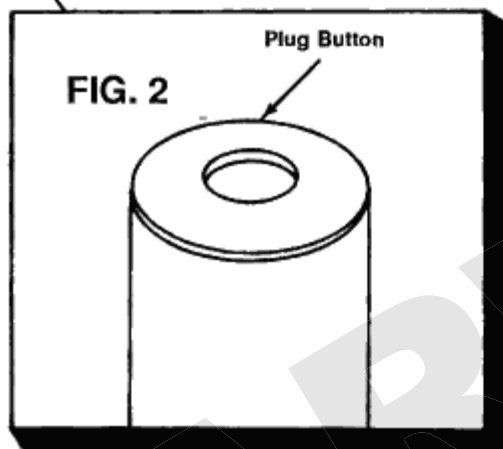
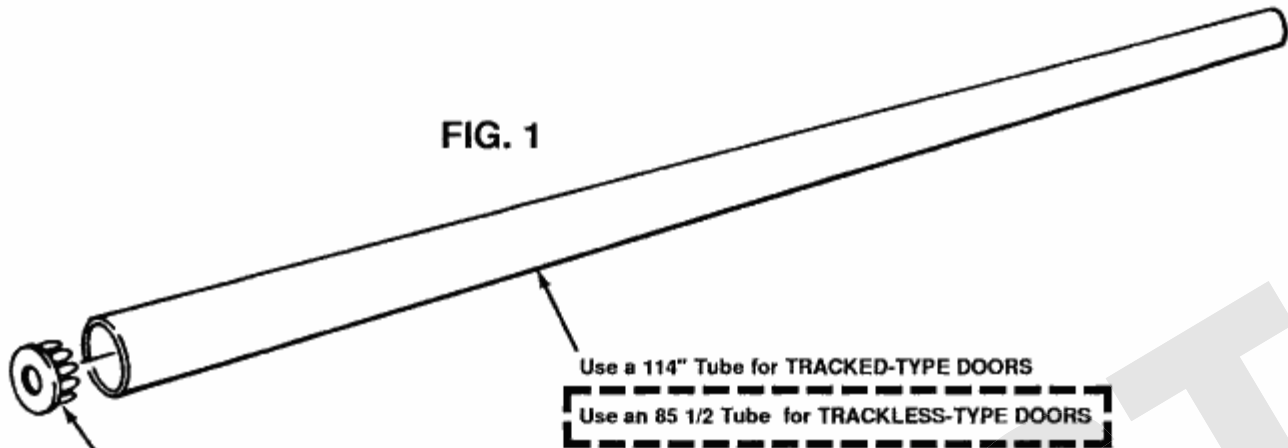

To protect the power unit during assembly and installation, use one of the cardboard panels packed with the unit. Locate the radio transmitter inside the packing material and set it aside in a safe place.

- A. Insert the plug button into the end of the assembled tube sections. Make sure it is fully seated. See Figs. 1 & 2.
- B. Slide the traveler onto the tube assembly making sure the arrow on the traveler marked () points towards the idler assembly.
- C. Insert the end of the tube assembly that has the plug button, into the tube support on top of the power unit. Slide idler assembly onto opposite end of tube by hand as far as possible. See Fig. 3.

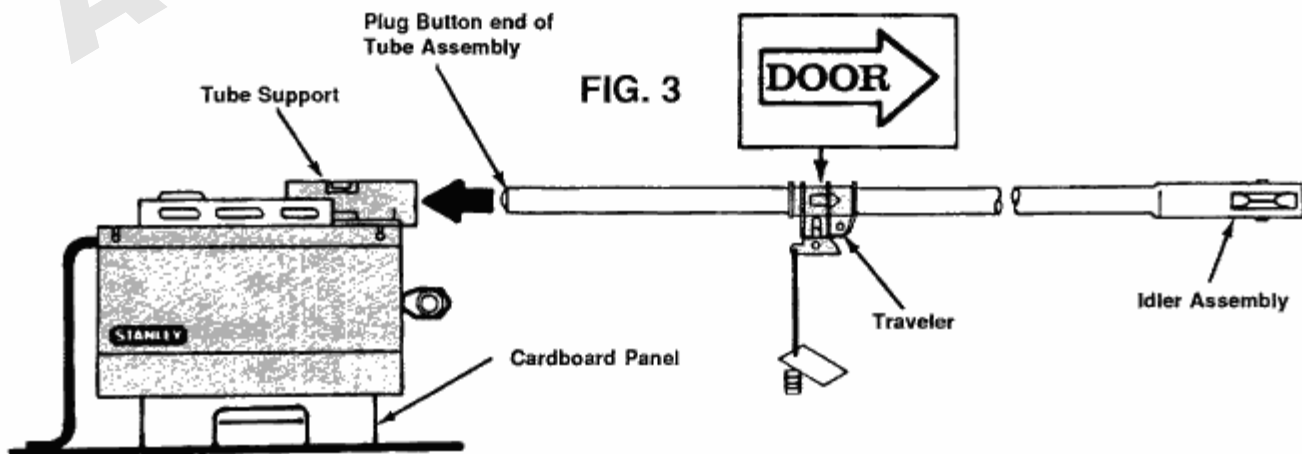

2 /ASSEMBLY cont.

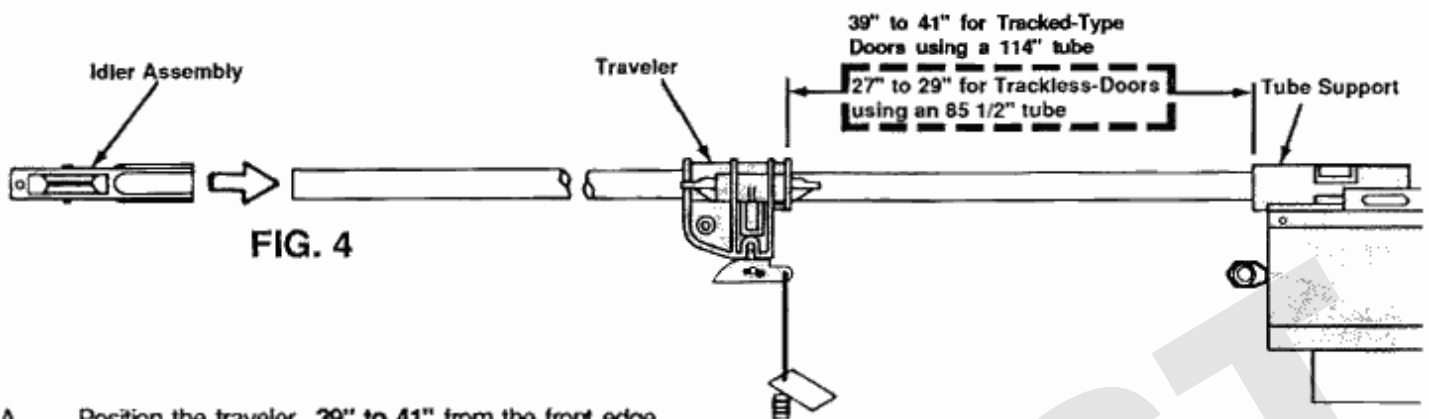

FIG. 4

- A. Position the traveler 39" to 41" from the front edge of the tube support on the power unit for Tracked-Type Doors.

Position the traveler 27" to 29" from the front edge of the tube support on the power unit for Trackless-Type Doors.

- B. Using a master link assembly, secure the loose end of the chain to the traveler carrier, as shown in Fig. 6. **MAKE CERTAIN THAT THE MASTER LINK RETAINING CLIP IS POSITIONED ON TOP.**
- C. Carefully unroll the chain towards the power unit. Loop chain around drive sprocket on top of power unit and continue to unroll chain (or chain/cable) until you get to the end. Check to **BE SURE** the traveler is the correct distance from the tube support edge. If not, reloop chain around drive sprocket. See Fig. 7.

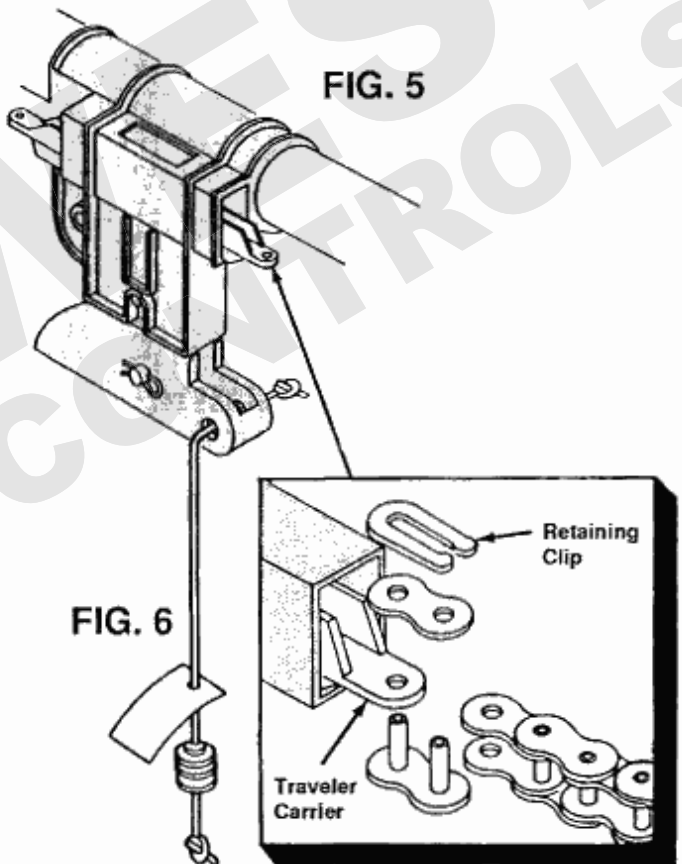
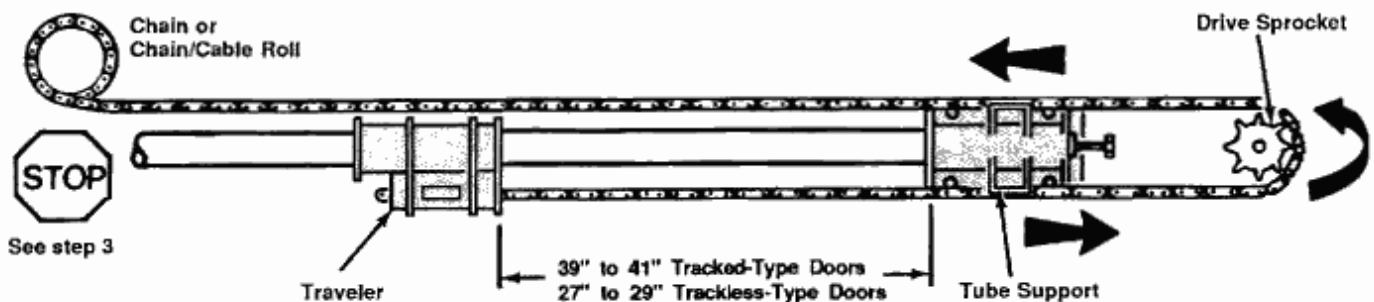

FIG. 5

FIG. 6

STOP! Read Step 3A on page 9 before proceeding.

It is very important that the traveler is positioned correctly.



See step 3

3 / ASSEMBLY cont.

- A. Carefully unroll the chain (or chain/cable) off of the cardboard tube in a straight line. Feed loose end of chain (or cable) through the idler assembly. Continue pulling loose end through idler assembly until it can be attached to the traveler carrier. See Fig. 8.
- B. Secure loose end to the traveler with the master link assembly. **MAKE CERTAIN THAT THE MASTER LINK RETAINING CLIP IS POSITIONED ON TOP.**

IMPORTANT: Make certain the traveler is positioned the correct distance from the end of the tube support. If not, remove master link and repeat steps 2A through 3B.

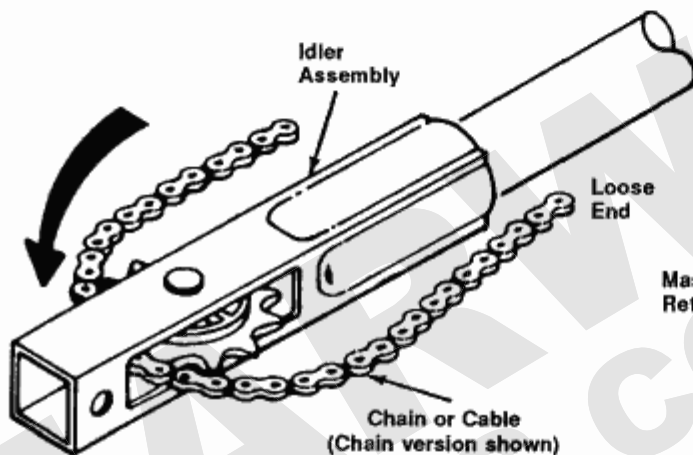

NOTE: BEFORE PROCEEDING, PLEASE NOTE THAT WHEN ADJUSTING THE CHAIN, THERE SHOULD BE A SLIGHT CHAIN SAG, ABOUT 1/2 INCH BELOW THE MID-POINT OF THE TUBE.

- C. Remove tape from chain adjustment screw. Adjust the chain tension by tightening the adjustment screw located at the rear of the tube support. (Clockwise rotation will tighten the chain, counterclockwise will loosen). See Fig. 9. Be careful not to bend the screw when adjusting.
- D. Install the chain guard over the drive sprocket by pressing down until its tabs snap into frame.

NOTE: THE INFORMATION TAG DESCRIBES HOW TO MANUALLY DISCONNECT THE OPENER FROM THE DOOR. PLEASE READ IT NOW BECAUSE FURTHER ON IN THE INSTRUCTIONS YOU WILL BE INSTRUCTED TO "DISCONNECT" OPENER.

TRAVELER DISTANCE FROM TUBE SUPPORT:

39" to 41" - Tracked-Type Doors using a 114" tube

27" to 29" - Trackless-Type Doors using an 85 1/2" tube

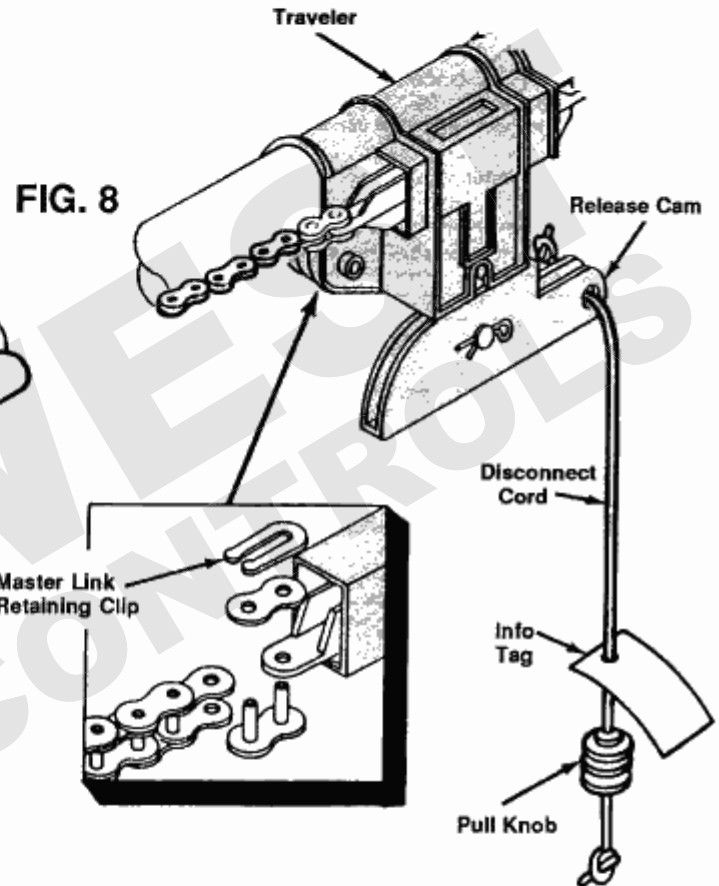
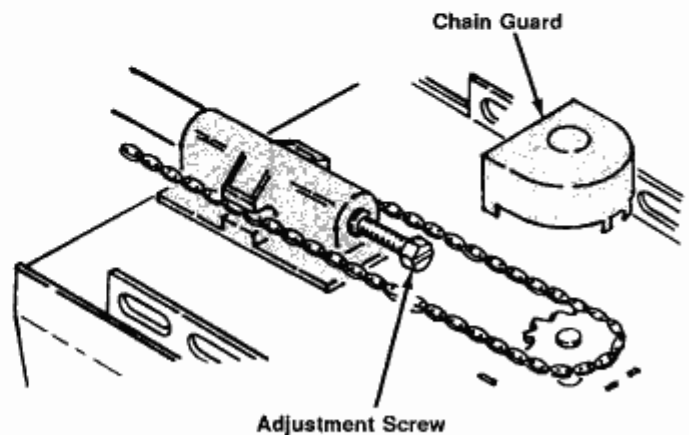

FIG. 9



4 / INSTALLATION

IMPORTANT! IT IS CRITICAL THAT YOU IDENTIFY WHAT TYPE OF DOOR YOU HAVE AS IT WILL MAKE A DIFFERENCE IN THE WAY YOUR OPENER IS INSTALLED, SEE PAGE 5.

- A. Locate the centerline of the door. Mark the centerline of the door on the header above the door and the top of the door. See Fig. 10.

**SPECIAL INSTRUCTIONS!
TRACKLESS-TYPE DOORS ONLY
6" ABOVE HIGH-RISE OF DOOR**

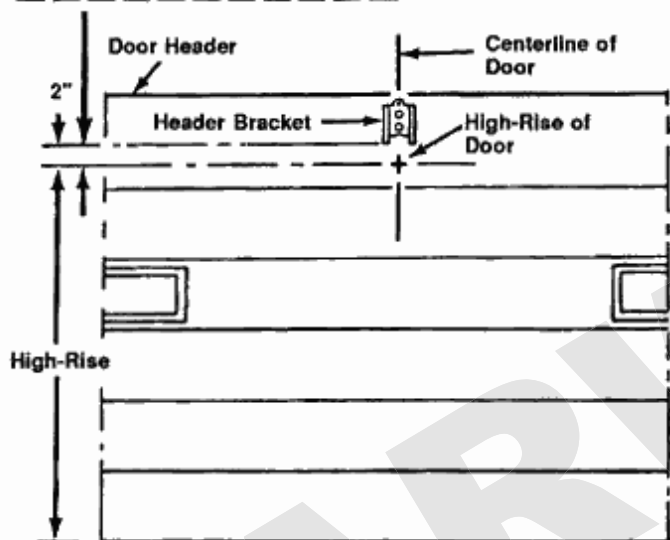

FIG. 10

- B. Slowly raise the door. When it reaches its high-rise point (highest distance off the ground when door is opening), place a support (prop) under the door to hold it at that position. Measure the distance from the floor to the top edge of door. See Fig. 11. Remove support and lower door.

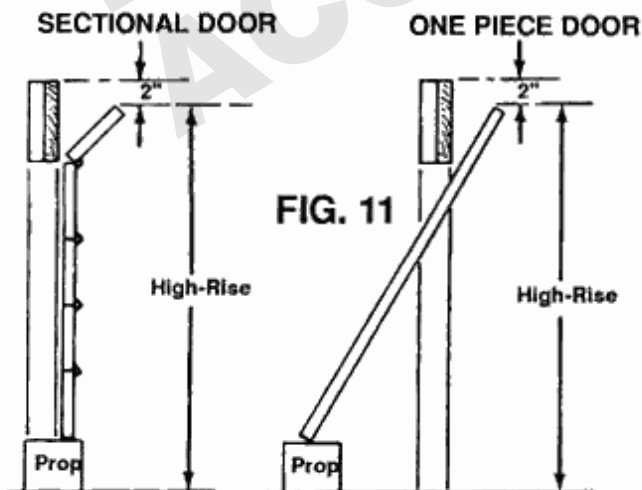

FIG. 11

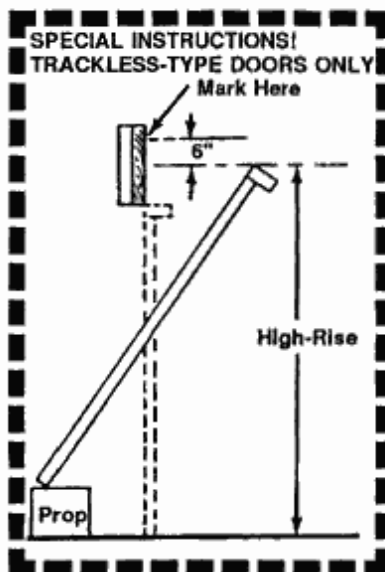

FIG. 13

- C. Add two (2) inches to the distance measured for high-rise for **Tracked-Type Doors**.

Add six (6) inches to the distance measured for high-rise for **Trackless-Type Doors**.

Using this new figure, measure up from floor and mark that point on the door header. Locate the header bracket at that point and directly on the centerline mark. (The header bracket may be mounted higher, but do not go any lower.) See Fig. 11.

NOTE: A nail may be used to temporarily hold the header bracket in place.

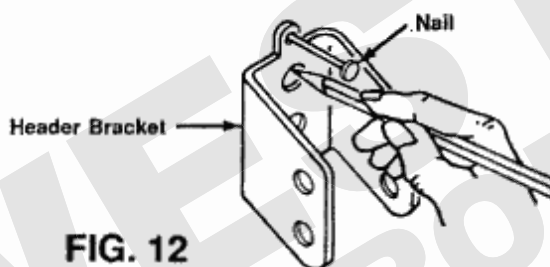
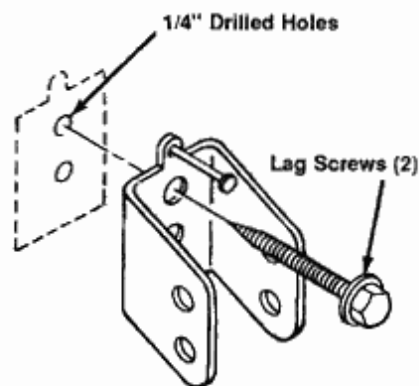

FIG. 12

- D. Holding the header bracket securely in position, mark the two holes of the header bracket on the door header. See Fig. 12.
- E. Using a 1/4" drill bit, drill pilot holes in the door header, using the marks as a guide. See Fig. 13.
- F. Secure the header bracket to the door header with two lag screws. Make sure bracket is tightly secured.

NOTE: In some types of garages, there may be a steel channel across the door header. If this channel is there, drill 3/8" holes in the channel, and 1/4" holes in the door header.



5 / INSTALLATION cont.

- A. Place the power unit on the floor and raise the idler assembly up to the header bracket. See Fig. 14.
- B. Using the 2" clevis pin and a lock clip, secure the idler assembly to the header bracket. See Fig. 15.

NOTE: The header bracket is designed with an additional positioning hole if height adjustment is necessary.

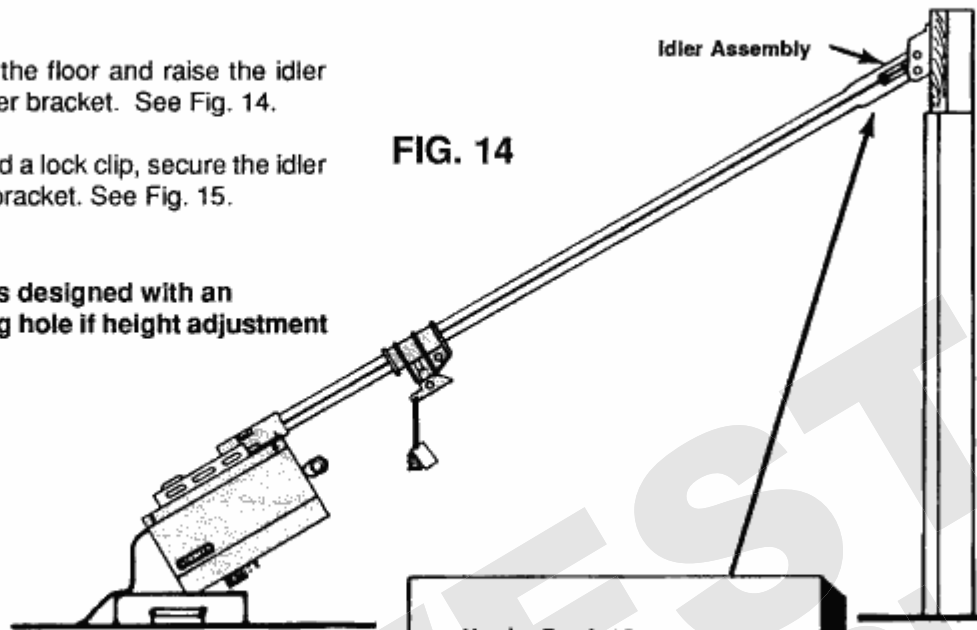

- C. Carefully raise the power unit and set it on a ladder or other suitable prop. See Fig. 16. Unit should be high enough to clear door when fully opened.
- D. Pull the disconnect cord down and slide the traveler assembly toward the power unit.

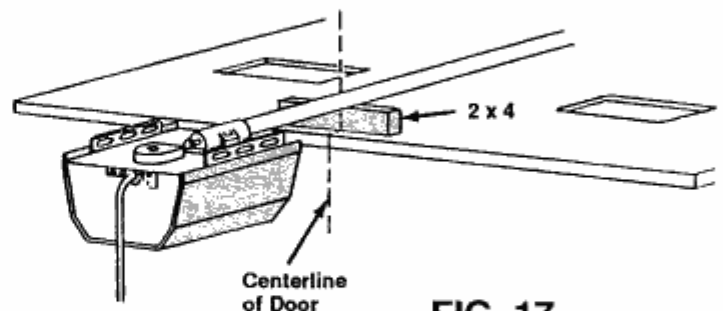
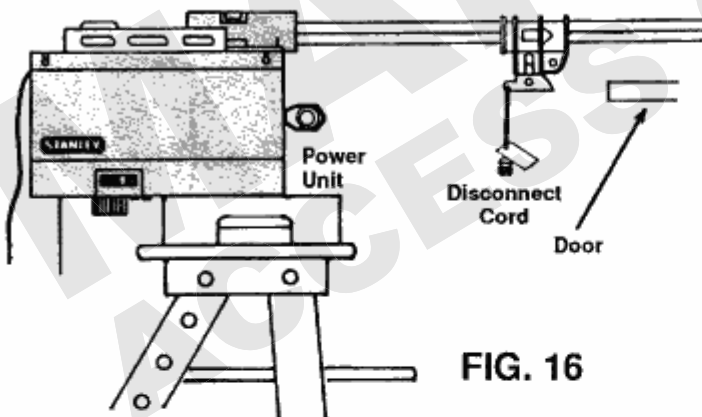
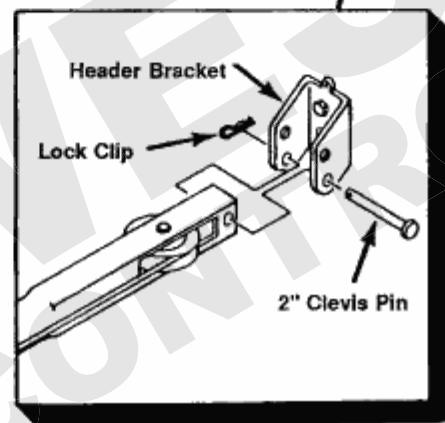

ONE PIECE AND SECTIONAL TRACKED DOORS ONLY:

- E. Raise the door to the full open position and place a 2" x 4" board (on edge) between the tube and the door. The 2" x 4" will ensure that the tube assembly will have enough clearance when the door is opening. Set the operator so that the tube rests on the 2" x 4" directly in line with the center of the door. See Fig. 17.

6 / INSTALLATION cont.

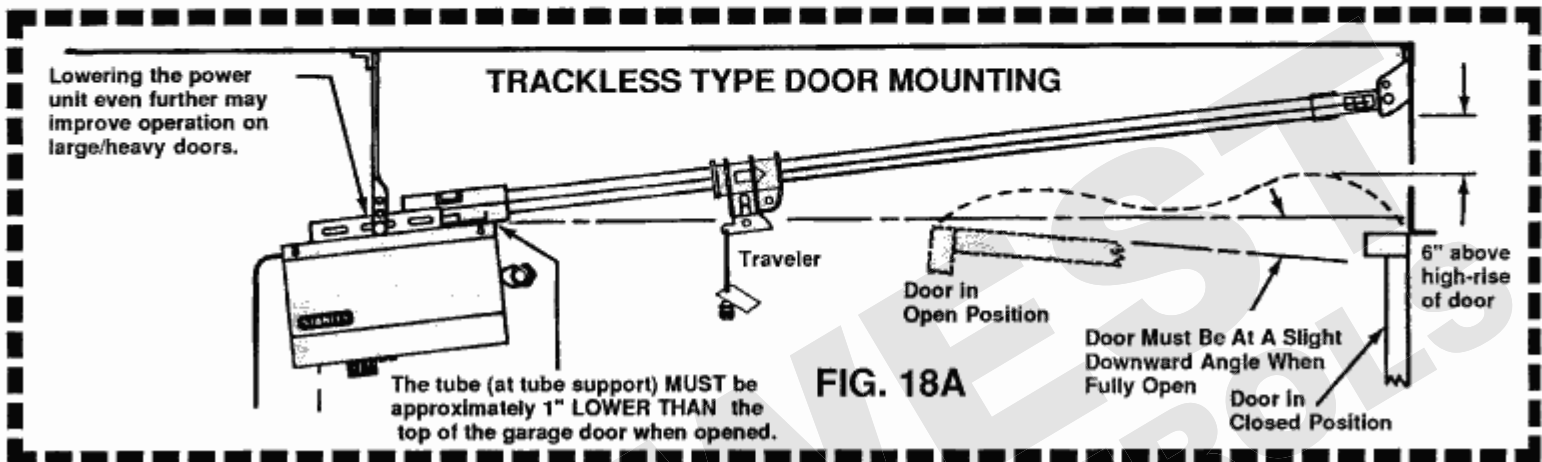
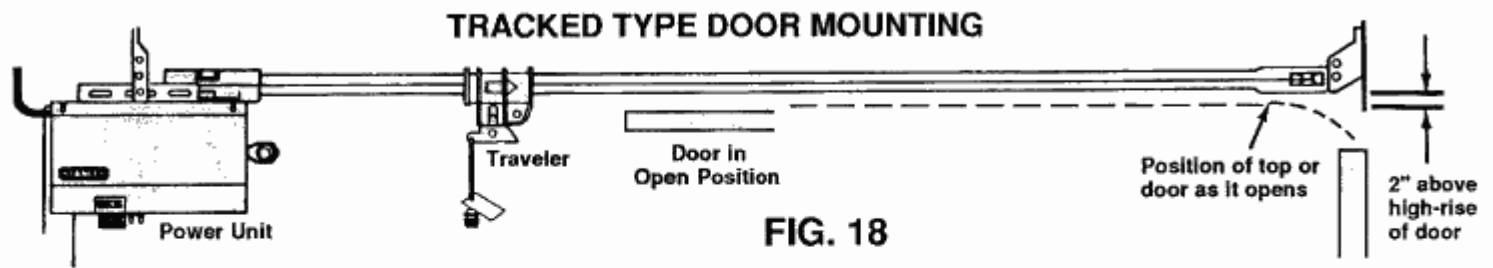
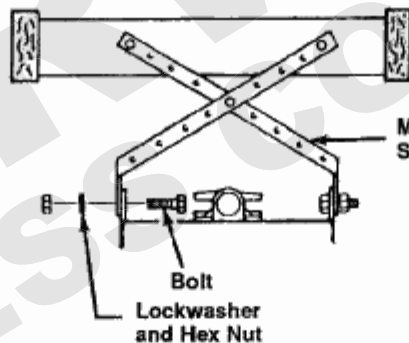
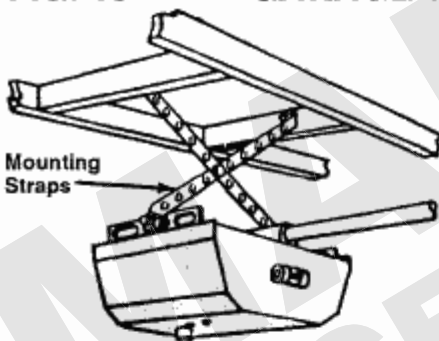
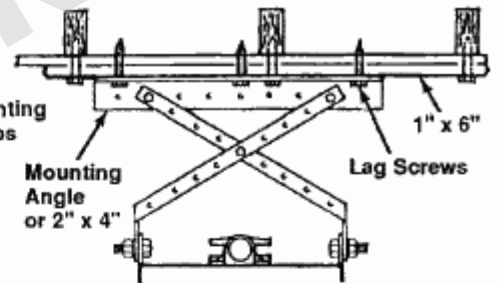

FIG. 19

GARAGE WITH OPEN BEAMS



GARAGE WITH FINISHED CEILING



SECURING POWER HEAD:

GENERAL INFORMATION: Mounting instructions for the power unit must, of necessity, be somewhat general in nature due to the many different ceiling designs found in various residential and geographical areas. Custom-designed garages may have a finished ceiling of gypsum, sheet board, or finished tongue and groove style lumber. In other instances, unfinished ceiling types will have exposed overhead wood beams, 2" x 4", or 2" x 6" rafters, joists, etc. Due to these construction variances, every power unit installation could be slightly different with different circumstances arising for each specific mounting application.

The main concern in mounting the power unit is that the installation be securely mounted for operational strength, rigidity and safety.

For finished ceilings, a section of 1" x 6" board can be secured to span the distance between ceiling rafters. The power unit can then be mounted directly to the board using the mounting angle and straps shown in Figs. 18 or 18A. If necessary, lag screws, longer than those furnished with the opener, or expansion bolts can also be used. Basic carpentry procedures, coupled with a little

pre-planning, should be all that is required to mount the power unit. If needed, a local carpenter can be contacted to provide whatever assistance is required.

- A. Mount the power unit to an overhead beam or ceiling. See Fig. 19. For mounting, use lag screws, hex head bolts, hex nuts and lockwashers. (Lag screws are for use in overhead wood beams or ceilings; hex head bolts and nuts are for mounting straps and angle.) Additional 2 x 4's may be needed for proper installation.

Mounting straps can be easily bent and cut to conform to whatever configuration that may be required.
- B. Once power head is securely mounted, remove all supports and ladders.
- C. Operate the door manually several times to ensure that the door travels freely and does not contact any part of the tubes. Top edge of door should clear the tube sections by at least one inch.

Do not allow door to hit the traveler.

7 / INSTALLATION cont.

- Assemble the L link to the bar link, as shown in **Fig. 20** for tracked type doors and **Fig. 21** for trackless type doors. Use two (2) hex bolts, lockwashers and hex nuts to secure the links.
- Attach the door bracket to the L link and bar link assembly. Use the shoulder bolt, lockwasher and hex nut. Make sure it is assembled as shown.
- Attach the L link and bar link assembly to the traveler. Secure the assembly to the traveler by inserting the 1 inch long clevis pin through the traveler and the assembly. Insert a lock clip through the small hole in the clevis pin. Assemble as shown in **Fig. 20** for tracked type doors or **Fig. 21** for trackless type doors.
- Pull the disconnect cord down and cock it (towards the door). Move traveler assembly toward the door.

FOR TRACKED TYPED DOORS ONLY

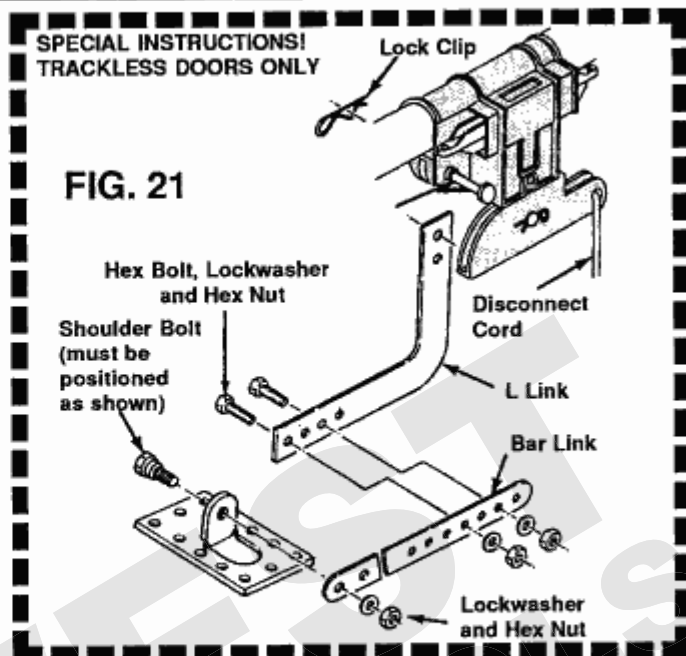
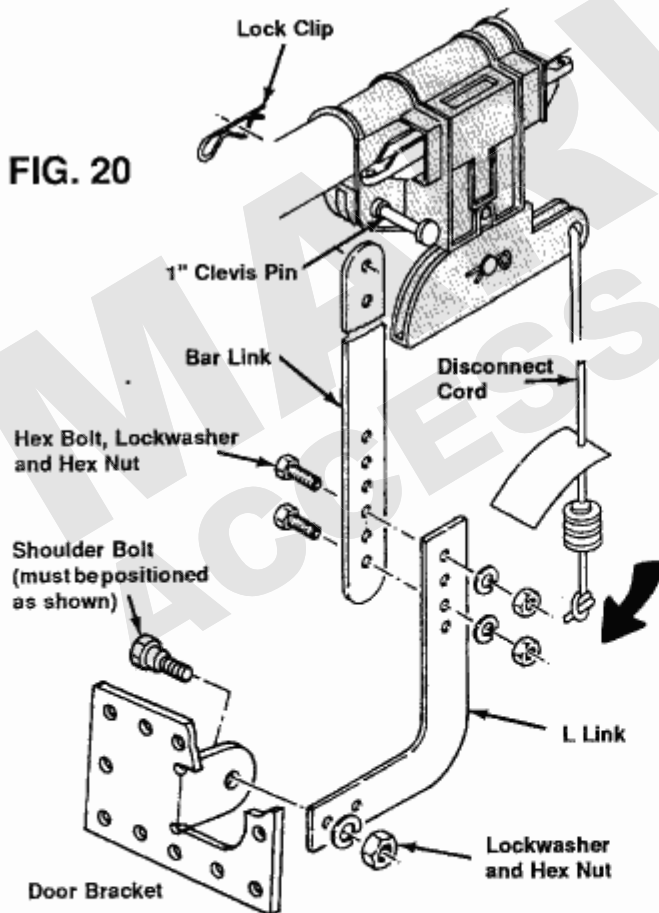

DOOR REINFORCEMENT

Lightweight fiberglass, aluminum and steel doors will require reinforcement to avoid damage to door and insure proper operation of the safety reverse system. A common way is to secure support angles along the top and bottom rails, inside of the top panel of the door. Then, to these two support angles, secure another angle vertically. The door bracket is then secured to this vertical support angle. It is important that the top and bottom support angles straddle and extend at least 8" beyond the left and right stiles. This minimizes bowing of the door besides spreading the load forces as the door is being moved by the operator. See Fig's. 22 and 23.

CAUTION: The addition of these braces may affect the balance of the door. After installation, check for proper manual operation and have the door re-balanced if necessary.

METAL OR FIBERGLASS SECTIONAL DOORS

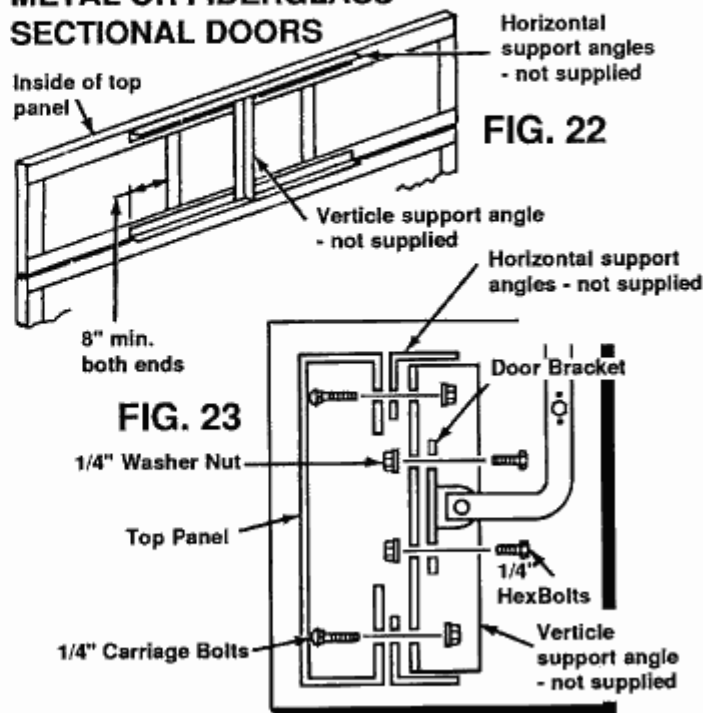

8 / INSTALLATION cont.

- E. Position the door bracket near top of door, as close as possible to the center of the top door roller and mark the two door bracket holes on the door. On sectional doors, the door rollers should be 3" to 6" from the top of the door. If they are not, simply position the door bracket 3" to 6" below the top of the door. See Fig. 24.
- F. Move the traveler back and drill two (2) 1/4" holes through the door at the marked hole location.
- G. Move traveler assembly toward the door and attach door bracket to door. Use hex bolts or carriage bolts to securely fasten bracket to door. See Fig. 25.
- H. Manually open the door to assure unobstructed movement. **NOTE: When door is fully open the traveler should be at least 8" away from the power unit. If not, shorten the door linkage as required.**

FIG. 24

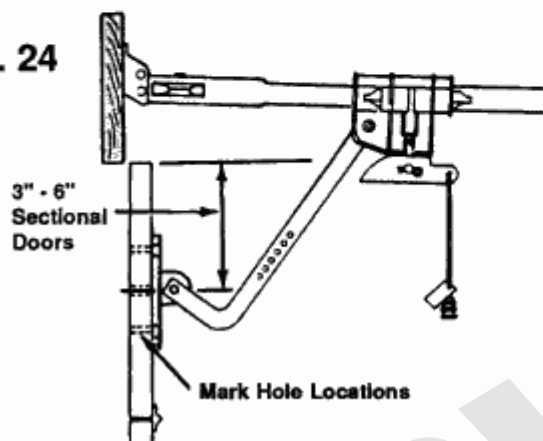
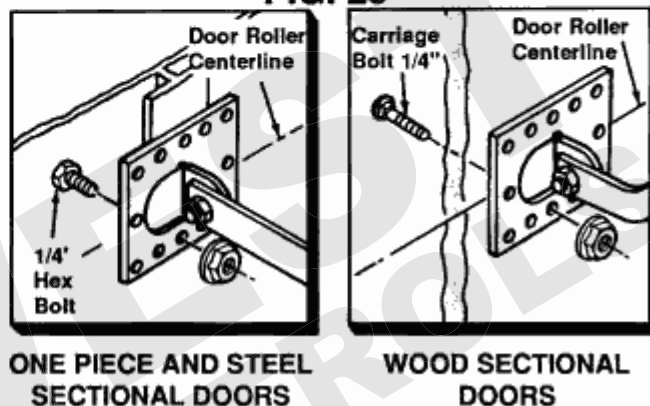

FIG. 25



SPECIAL INSTRUCTIONS! TRACKLESS DOORS ONLY

Position the door bracket on the top edge of the door, directly on the centerline of the door. Use a pen or pencil to mark the hole locations on the door. Drill (2) 1/4" holes through the door at the marked hole locations. See Fig. 24A.

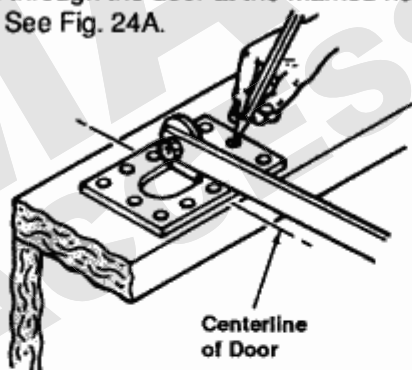
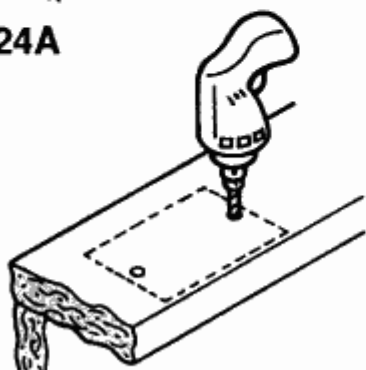
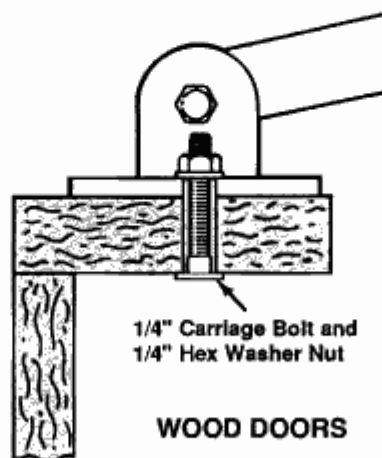
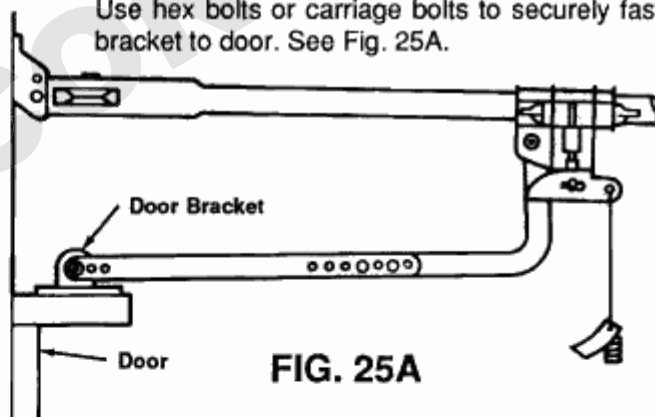

FIG. 24A



Use hex bolts or carriage bolts to securely fasten bracket to door. See Fig. 25A.



WOOD DOORS

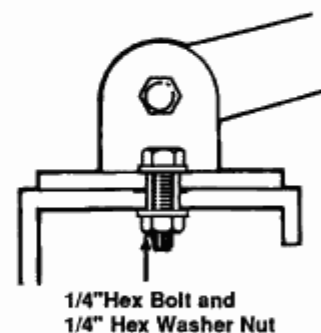

METAL DOORS

9 / LOCK REMOVAL



IMPORTANT: *The door opener provides for positive closing of the door. All existing door locks must be made inoperative. If existing door locks are locked while trying to use the opener, damage to opener and door could result.*

Pin or screw the existing lock mechanism in the "open" (unlocked) position. If necessary, the catch latches may be repositioned or the complete lock assembly may be removed.

FIG. 26

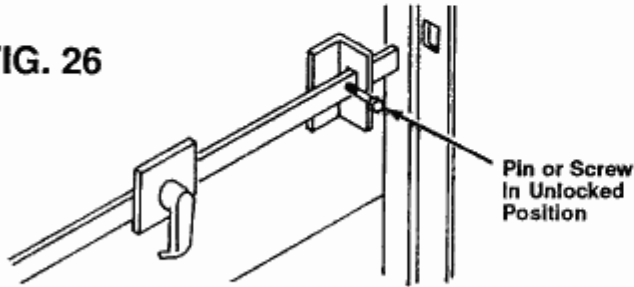

Because of the many styles of door locks, the illustrations show only two of the more common types.



IMPORTANT: *It is important that all ropes and cords, that could cause entanglement, be removed from the door.*

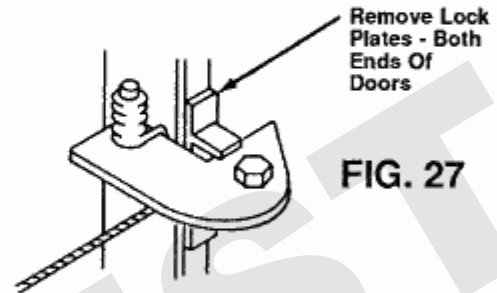

FIG. 27

10 / PUSHBUTTON INSTALLATION

- Strip about 1/4" of insulation off each end of pushbutton wire. Connect pushbutton wires to the two screws on rear of pushbutton as shown in Fig. 28.
- Locate pushbutton in a convenient location and attach with the two wood screws provided.
- Run wire from pushbutton to power unit. Use staples provided to secure wire. Do **NOT** staple through wires. This will cause a short. Do **NOT** place wire

close to the 120 volt power wires. Separate as far as possible. **NOTE:** If garage has more than one opener, keep pushbutton wiring separate as far as possible.

- Strip about 1/4" of insulation off the other end of wire and connect to terminal board at the rear of the power unit. See Figs. 29 and 30.
- Mount caution label near the pushbutton. See Fig. 31.



IMPORTANT: *Mount the pushbutton higher than a child can reach and in a location where the door is easily visible.*



Never pass under a moving garage door.

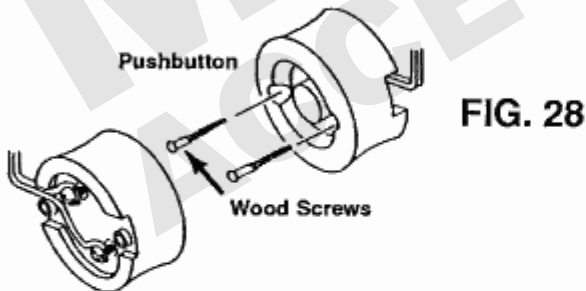

FIG. 28

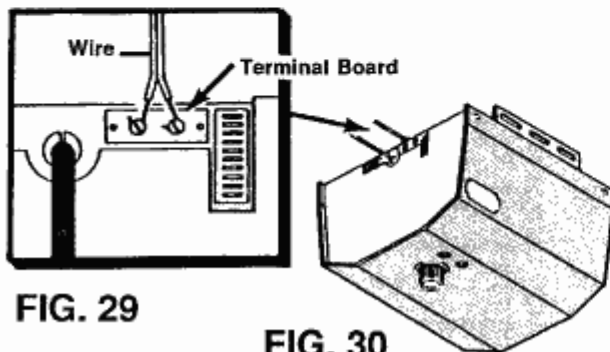

FIG. 29

FIG. 30

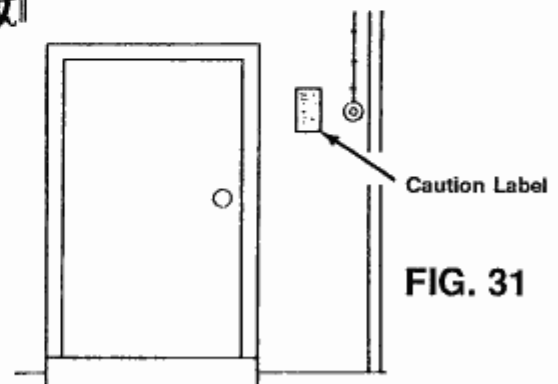

FIG. 31

11 / RADIO CODING INSTRUCTIONS



WARNING: KEEP TRANSMITTER OUT OF REACH OF CHILDREN.

ALL MODELS

- A. Locate the bank of digital code switches on rear panel of opener. With a pencil or pen, flip any combination of switches to set your own personal code. See Figs. 32 and 33.

NOTE: All odd numbered switches are factory set to the OPEN position. All even numbered switches are set to the ON position.

IMPORTANT: Do not set all switches in the same position. Do not, however, leave the switches in the "as-purchased" position.

NOTE: Some code switches are marked "ON/OFF." Others are marked "OPEN." If the switches on the opener differ from those in the transmitter, please note that the "OFF" position equals the "OPEN" position.

- B. Squeeze transmitter case as shown in Fig. 34 and remove side panel. With a pencil or pen, set the code switches in the identical positions (pattern) that you set the code switches on the rear panel of the opener. See Fig. 35.
- C. Replace access panel on transmitter.

NOTE: Small light on top of transmitter indicates when your transmitter is sending signal. If the light does not come on when pressing the transmitter button, check for a dead battery.

- D. Straighten the radio antenna and point it straight down. See Fig. 36.

FCC Radio Usage Limitations.

CAUTION: The garage door operator and all accessory radio equipment has been designed to Federal Communications Standards for Part 15 radio devices. Operation of this device is subject to the following conditions: (1) This device may not cause harmful interference; (2) This device must accept any interference that may be received, including interference that may cause undesired operation; (3) Changes or modifications not expressly approved by Stanley Home Automation, Division of The Stanley Works, could void the authority of users to operate this equipment.

FIG. 32

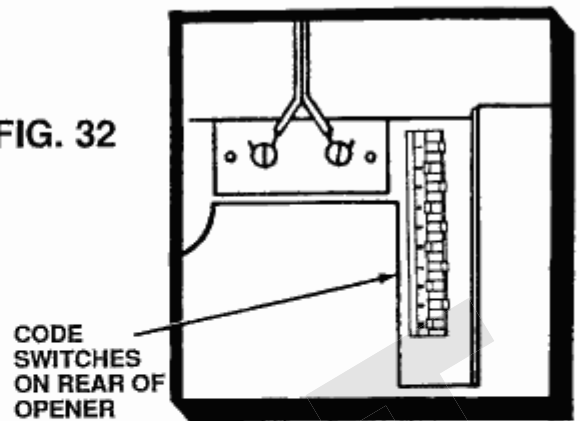

FIG. 33

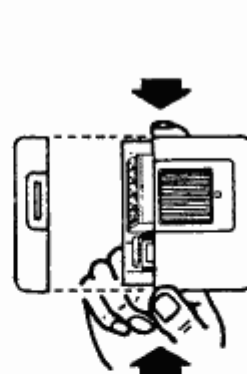
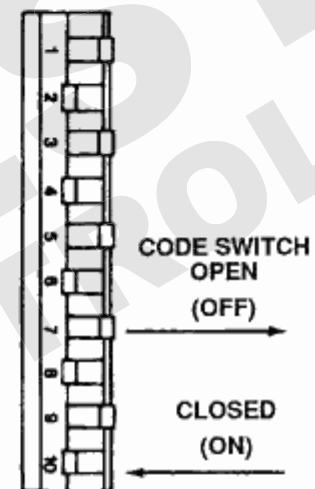

FIG. 34

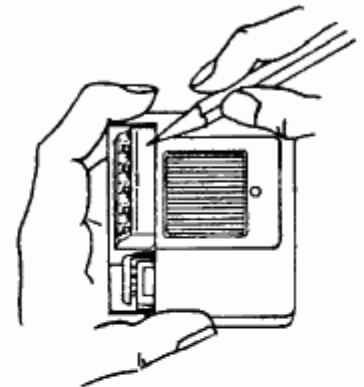

FIG. 35

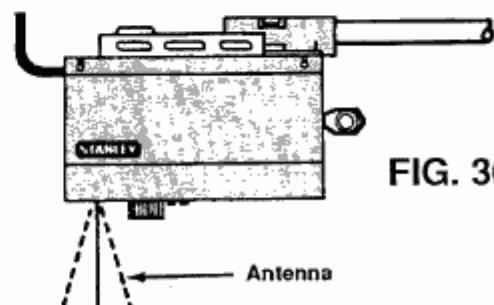

FIG. 36

12 / LIGHTING

SINGLE LIGHT SOCKET MODELS

Install one 100 watt light bulb into the light socket.
See Fig. 37.

DUAL LIGHT SOCKET MODELS

Install two 100 watt light bulbs into the dual lamp socket.
Install lamphouse using the knurled nut, already on the
lampsocket, to secure it. See Fig. 37A. Attach light switch
rope to chain.

NOTE: *The maximum total wattage must not be more
than 200 watts. It is suggested that rough service bulbs
be used.*

AUTOMATIC LIGHT OPERATION

ALL MODELS: The lights will come on when the door
opens or closes, and stay on for four to five minutes, then
automatically turn off.

SPECIAL LIGHT FEATURE "SAFE-T-SIGNAL"

Whenever any of the openers safety features are activated,
the lights on the opener will flash until the next push of either
the transmitter or pushbutton.

VACATION SWITCH: Feature present on some models

The "Vacation Switch" allows you to make the radio and
pushbutton controls inactive when placed in the
"OFF" position. When placed back in the "ON" position, the
light will blink once indicating the system is now functional.

WORK LIGHT: Feature present on some models

By pulling on the light switch rope, the lights on the opener
can be turned on or off. This switch cannot shut off the lights
when they are in the light time delay mode.

NOTE: *If the model is equipped with work light
operation, opener lights will not flash if work light is on.*

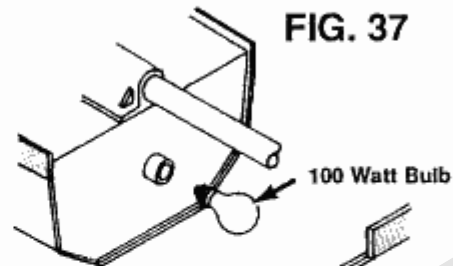
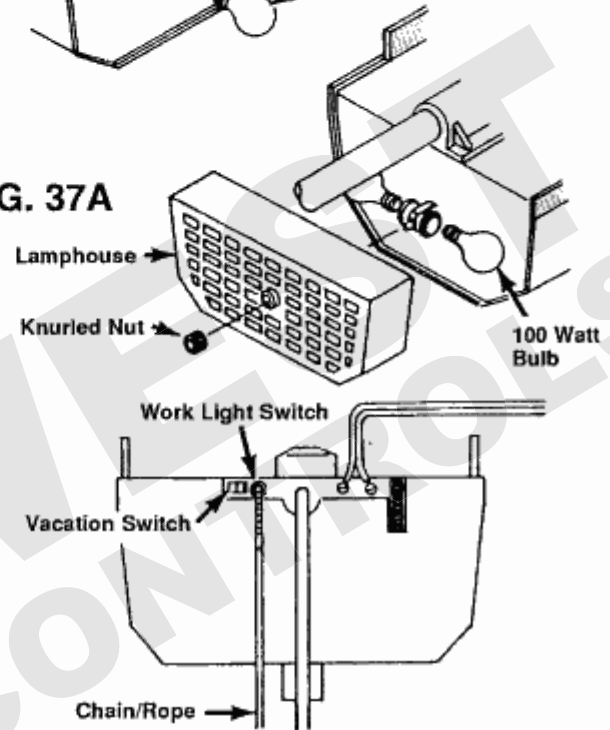

FIG. 37A



13 / POWER CONNECTION

**CONNECT CORD ONLY TO A PROPERLY GROUNDED
OUTLET. FAILURE TO DO SO MAY RESULT IN
POSSIBLE ELECTRICAL HAZARD OR DAMAGE TO
ELECTRONIC CIRCUITRY.**

PERMANENT WIRING INSTRUCTIONS:

NOTE: *Where required by local codes, opener must be
permanently wired.*



**Disconnect power at fuse box before
proceeding.**

- A. Remove cover from power unit.
- B. Remove electrical power cord from opener and black
plastic strain relief bushing. **NOTE:** Bushing can be
removed by compressing with pliers and then pulling
out.

- C. Attach white lead to silver colored terminal marked
L1, black lead to brass colored terminal marked L2,
and green grounding lead to ground screw using the
external tooth cup washer located in accessory bag.
Washer will retain the wire.
- D. Replace cover and switch power on at fuse box.

CUSTOMER NOTE: Services of a licensed electrician
can be obtained to perform the above permanent wiring.

SPECIAL NOTE ABOUT LIGHTNING:

All Stanley Garage Door Openers have "Voltage Spike
Protection" to protect against damage and erratic opera-
tion due to lightning or high amounts of power line noise.
Additional "Voltage Spike Protectors" can be purchased at
most electronic stores. **NOTE: No Voltage Spike Protector
can eliminate damage due to a severe lightning surge.**

14 / ADJUSTMENTS: SAFETY REVERSE, CLOSE AND OPEN POSITION

ENGAGE TRAVELER DETENT

- A. Pull the manual disconnect straight down and allow mechanism to engage in slot.
- B. Manually move door until traveler engages with traveler latch.



CAUTION: The opener will operate during the following steps. Insure nothing is in the path of door before proceeding.

NOTE: This operator is equipped with a thermal protector in the motor circuit. If during the following steps the unit shuts off and will not restart, wait 5-10 minutes for the motor to cool down, then continue adjustment.

REVERSE FORCE ADJUSTMENT (Large Knob)

NOTE: If the door is not obstructed, the opener will automatically shut off before the door reaches the floor.

- A. **PERFORMING THE OBSTRUCTION TEST:** Press transmitter button to close door (if door does not close, refer to Radio Coding Instructions). While it is closing, try stopping the door with both hands approximately 4 feet from the floor. **DO NOT STAND UNDERNEATH DOOR PATH.** The door should easily stop and then reverse direction to the previously open position.
- B. If the door reverses direction before you can obstruct it, the sensitivity adjustment must be decreased for proper operation. Turn the **SAFETY SENSITIVITY KNOB** 1/4 turn in the direction of decreased sensitivity (clockwise) and press the transmitter button again to close the door. Repeat this adjustment until the door easily reverses when obstructed by your hands, but stops before reaching the floor if not obstructed while closing.

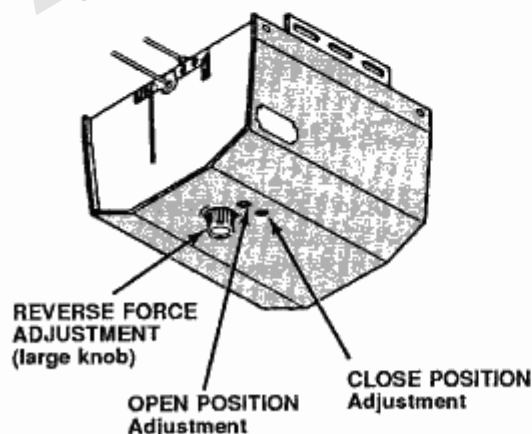

IMPORTANT:

DECREASING sensitivity (clockwise) INCREASES force applied to the door.

INCREASING sensitivity (counterclockwise) DECREASES force applied to the door.

CLOSE POSITION AND REVERSAL HEIGHT ADJUSTMENT (Small Black Knob only)

- A. With door open, press transmitter button to close the door. After the door stops, and the opener shuts off, locate the **BLACK** close limit knob on the bottom of the opener. See Fig. 38. Turn the knob **SLOWLY** in the direction of arrow (clockwise). The opener will start and the door will "inch" its way down as you turn the knob. When the door is fully closed, continue to turn the black close limit knob **VERY SLOWLY** until the door reverses off the floor and travels back to the open position. If the door does not open after one full turn, press transmitter button to open door, and again to close. The door should reverse when it meets the floor. If not, turn knob 1/4 turn clockwise in the direction of arrow and retest.
- B. With the door now in the open position, **SLOWLY** turn the Black close limit knob in the **OPPOSITE** direction of arrow (counterclockwise) 1/4 turn. Press transmitter button to close the door. If the door reverses from the floor, allow the opener to shut off and repeat above adjustment. Proceed when the door reaches the floor and the opener shuts off.

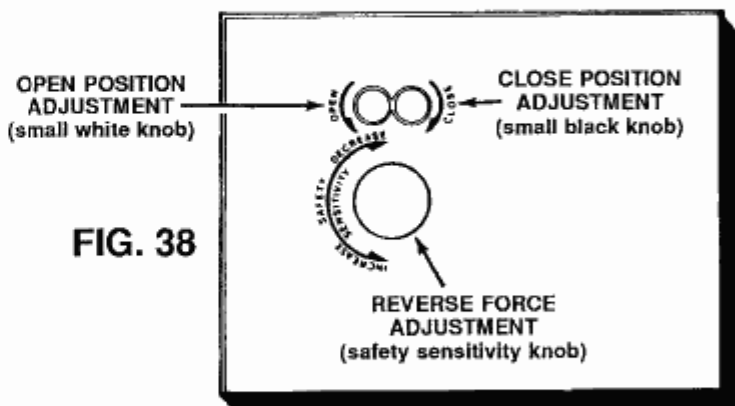

NOTE: The tube acts as a shock absorber during the opening and closing of your garage door. When the door is fully closed, there will be some tube bowing. This bowing minimizes the stress on the door and door hardware. See Fig. 39.

REVERSAL HEIGHT TEST



IMPORTANT: Check that the door will reverse off of a one inch high object placed on the floor. If not, **SLIGHTLY** turn the Black close limit adjust knob in the close (clockwise) direction and check again.

NOTE: If door still fails to reverse off object, discontinue use and contact the Stanley Customer Service Department.

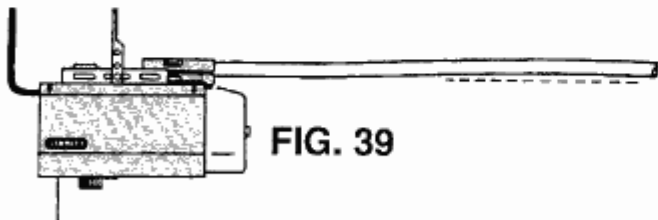

FIG. 39

OPEN POSITION ADJUSTMENT (Small White Knob only)

- A. Press transmitter to open door. After opener shuts off, locate the WHITE open limit knob on the bottom of the opener and turn it in the direction of arrow (counterclockwise). The opener will start and the door will inch its way open as you turn the knob. Continue turning knob until the door reaches the fully open position. Do not allow opener to run the door past the fully open position. To check this, pull disconnect cord and release door. If door coasts down slightly, readjust by turning White limit knob 1/2 turn in the opposite direction (clockwise). Reconnect door, press transmitter to close door. Reopen and check door again for fully open position.

MAINTENANCE CHART: Remove paper backing and attach **Door/Opener Maintenance Chart** in a visible location on garage door.

THAT'S IT — YOU'RE DONE! Please take time to read the remaining pages and fill out the warranty registration card.

PERIODIC INSPECTIONS (Check these items monthly)

LUBRICATION: For easy operation and long life, lubricate all moving parts of your door with light oil several times yearly, including roller shafts. Do not lubricate tracks or surfaces of nylon rollers.

DOOR BALANCE TEST: Check door balance at 3/4 open, mid-point and 3/4 closed positions. Refer to "Door Test" in manual.

SAFETY: The safety reverse adjustment is the **single most important step** in the installation of your garage door opener. The door must reverse when it comes in contact with a 1" high solid object placed on the garage floor. If door does not reverse refer to the **Closed Position and Reversal Height Adjustment** in this manual or contact a door system professional. Failure to comply with this requirement may result in serious or fatal injury to anyone trapped by a closing garage door.

OPEN AND CLOSED SETTINGS: Make sure the open and closed limits are properly adjusted. Refer to manual.

MANUAL DISCONNECT: Pull the red disconnect knob to ensure the door can be released from the opener.

HARDWARE: Inspect the chain/cable tension and re-tighten all nuts and bolts.



CAUTION: Discontinue usage and contact an authorized Stanley dealer or the Stanley Customer Service Department anytime a malfunction is observed.

ACCESSORIES

DIGITAL TRANSMITTER

Ten position, rocker type with a possibility of 1,024 code combinations. This allows you to program your own personal code settings, completely unique from your neighbor's code. Reprogram your combinations as necessary. Compatible with all current Stanley digital openers.

Order Number 370-1915

EMERGENCY DISCONNECT LOCK

Used when you have no separate entrance to the garage. Should there be a power failure, it will disconnect the opener from outside the garage, enabling you to operate your door manually.

Order Number 370-1974

ELECTRIC KEYSWITCH

Used when you are out of your car and want to enter your garage. By inserting a key and turning it, the door will open or close.

Order Number 370-1961

DIGITAL KEYLESS ENTRY

This unique, multi-code entry system with telephone-type pushbutton keyboard will allow you to open or close your door from outside the garage by pressing your personal code.

Order Number 370-2069

TROUBLESHOOTING: PROBLEM/SOLUTION

OPENER DOES NOT WORK

1. Make sure power cord is plugged into a properly grounded 3 prong 120 volt outlet.
2. Plug in a drill or other electrical tool to test for power.
3. If opener has been cycled several times, the motor overload protector may be activated. Wait approximately 10 minutes for the motor to cool and then try again.
4. Some openers have a "Vacation Switch" that turns power OFF. Make sure the switch is in the ON position.
5. If door is severely out of balance, the opener may not be able to exert enough force to move it. Make sure all locks are removed. Pull the manual disconnect cord to release the door from the opener. Check to see if the opener will operate if not connected to the door. If opener now operates review "Door Test" section of this manual.

TRANSMITTER DOES NOT WORK

1. Review the "Radio Coding" instructions in this manual. Someone else's radio controls may be interfering with yours. Try changing your code.
2. The battery in your transmitter may be dead or weak. Replace it with a 9 volt battery of the same type.

PUSHBUTTON DOES NOT WORK

1. Make sure the pushbutton wires are not touching each other at the terminal strip on opener or at the pushbutton.
2. If the wires are not touching each other and the problem still exists, disconnect the wires from the back of the opener and "short" across the two pushbutton screws using a key or screwdriver. If opener now operates, the pushbutton wires are probably shorted or broken. It is recommended that they be replaced. **NOTE:** Keep pushbutton wires away from 120 volt power lines. If the garage has two openers, separate the pushbutton wiring from each unit as far as possible.

TRANSMITTER HAS SHORT RANGE

1. Battery inside transmitter may be weak. Replace it with a new one of the same type.
2. Try moving or coiling the antenna wire on the opener.
3. Change radio code. Review "Radio Coding" instructions. **NOTE:** CB radios, computer equipment, powerful communication signals, and other door openers may cause undesirable interference and shorten radio range. Read "FCC Radio Usage Limitations" in the "Radio Coding Instruction" section of this manual.

LIGHTS FLASHING ON OPENER

1. This is caused by activating the "Safety Sensitivity" system that is controlled by the **reverse force adjustment** on the bottom of the opener. If it requires more force to move the door than the opener can supply this system will activate. This may be caused by a poorly operating door or an obstruction. Review "Door Test" in this manual.
2. If something obstructs the door while closing, it will reverse and open - lights will flash. If something obstructs the door while opening, it will stop - lights will flash. Review the **Reverse Force Adjustment Section** in this manual.

IMPORTANT:

**DECREASING sensitivity (clockwise)
INCREASES force applied to the door.**

**INCREASING sensitivity (counterclockwise)
DECREASES force applied to the door.**

DOOR CLOSSES - THEN OPENS WHEN REACHING THE FLOOR

1. Is there a rake handle, garden hose, snow, ice, etc. obstructing the door? Remove the obstruction then try operating the system again.
2. Due to climatic conditions many concrete floors will heave or sink. Turn the (small black) **close position adjustment** 1/2 turn opposite the direction of the arrow on the cover, then review the **close position and reversal height adjustment** instructions in this manual.

OPENER ACTIVATES BY ITSELF

1. Review the "Pushbutton Does Not Work" and "Transmitter Does Not Work" troubleshooting sections. Remember, somebody may be using the same radio code as you. **DO NOT** leave radio in **factory set** position.
2. Is the transmitter button or wall mounted pushbutton stuck down?

EXCESSIVE TUBE BOW

1. Check to see that the powerhead is securely mounted and the door operates freely. Review "Door Tests" in this manual. Is something obstructing the door?
2. Review "Close Position and Reversal Height Adjustment" in this manual.

LIGHT STAYS ON

1. The light time delay on the opener will keep the light on for approximately 4 1/2 minutes after the system has been activated, then will turn it off automatically.
2. If opener has a **worklight** switch wait 5 minutes after activating the opener for the light time delay "time out", then pull on the work light switch cord to turn lights off.

NOT ENOUGH OPEN OR CLOSE POSITION ADJUSTMENT

1. If you operated the unit before it was completely installed or if you did not position the traveler the correct distance from the tube support, the limits and traveler may be out of synchronization.
2. Turn off power, remove and relocate traveler by disconnecting chain from sprocket, re-assemble and try adjusting again.

SOMETHING BROKE - NEED ASSISTANCE?

Identify the part in the instruction manual (if required) then contact your local Stanley dealer or use the free Stanley 800 Help Line.

NOTES:

1. Reference the proper pages in this manual for all adjustments and settings.
2. If the problem has been located in the radio controls (other than batteries) return **only** the transmitters and the control board. **Do not** return the complete opener.

TROUBLESHOOTING cont.

CONTROL BOARD REPLACEMENT:

DISCONNECT POWER BY REMOVING ELECTRICAL PLUG OR FUSE

WEAR SAFETY GLASSES

- A. Loosen the four wrapper cover screws and remove cover from opener. **NOTE: Limit actuator knobs will pull off of actuator shafts when cover is removed. Remove limit knobs from cover by squeezing plastic tabs on side of limit knobs. See Inset.**
- B. Remove the four screws holding the control board.
- C. Carefully disconnect the electrical connector and remove control board.

TO REPLACE THE CONTROL BOARD IN OPENER:

- A. Connect electrical connector to control board.
- B. Install and tighten the four (4) screws that secure the control board. **NOTE: Make certain that the metal leaf is positioned between the two plastic posts that protrude through the cut-out slot in the control board.**
- C. Replace the wrapper cover on opener. Make sure that antenna is inserted and pulled through hole in wrapper cover. Tighten the four cover screws.
- D. Reinstall limit actuator knobs by centering on actuator shafts and pushing in on knobs until they click and lock into position. Place the white knob on the open actuator and the black knob on the close actuator.
- E. Refer to "Radio Coding Instructions" to set proper radio codes.
- F. Reconnect power.

NOTE: If trouble has been located in the radio controls (other than batteries), return ONLY the transmitter(s) and control board, not the complete opener!

FIG. 40 Wrapper Cover Screws (4)

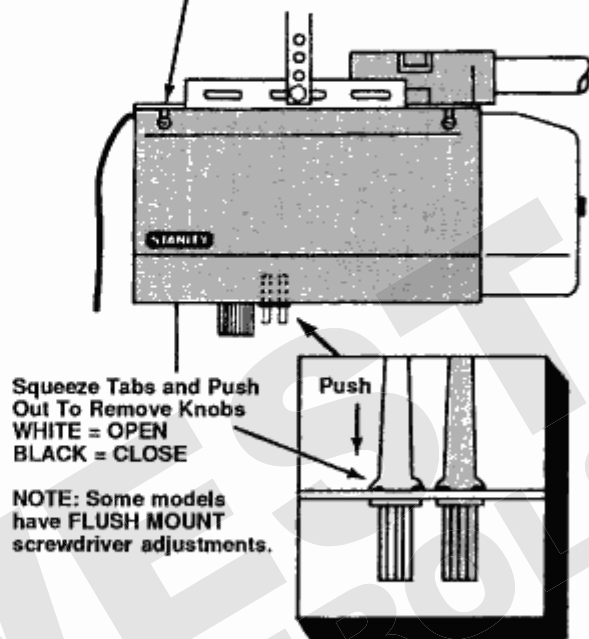
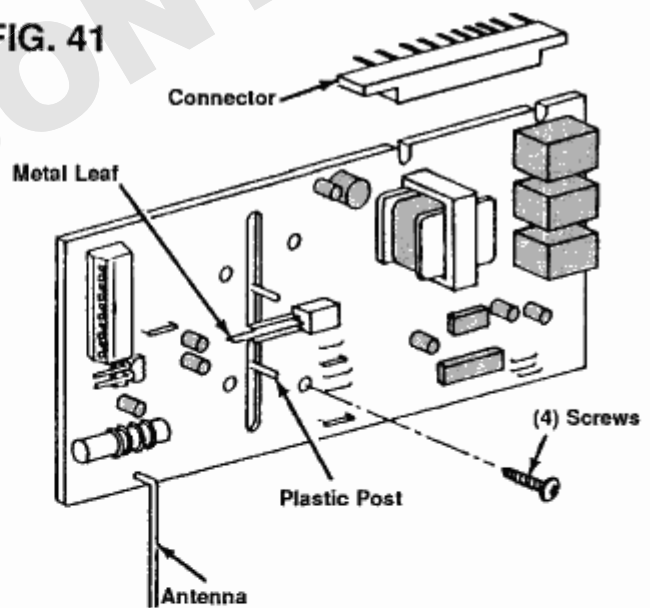

FIG. 41



NOTE: CONTROL BOARD ILLUSTRATION MAY VARY.

FOR ADDITIONAL INFORMATION ON ACCESSORIES OR SERVICE
Contact your local dealer
carrying Stanley
garage door openers

PARTS LIST

NOT ALL PARTS SHOWN ARE SUPPLIED

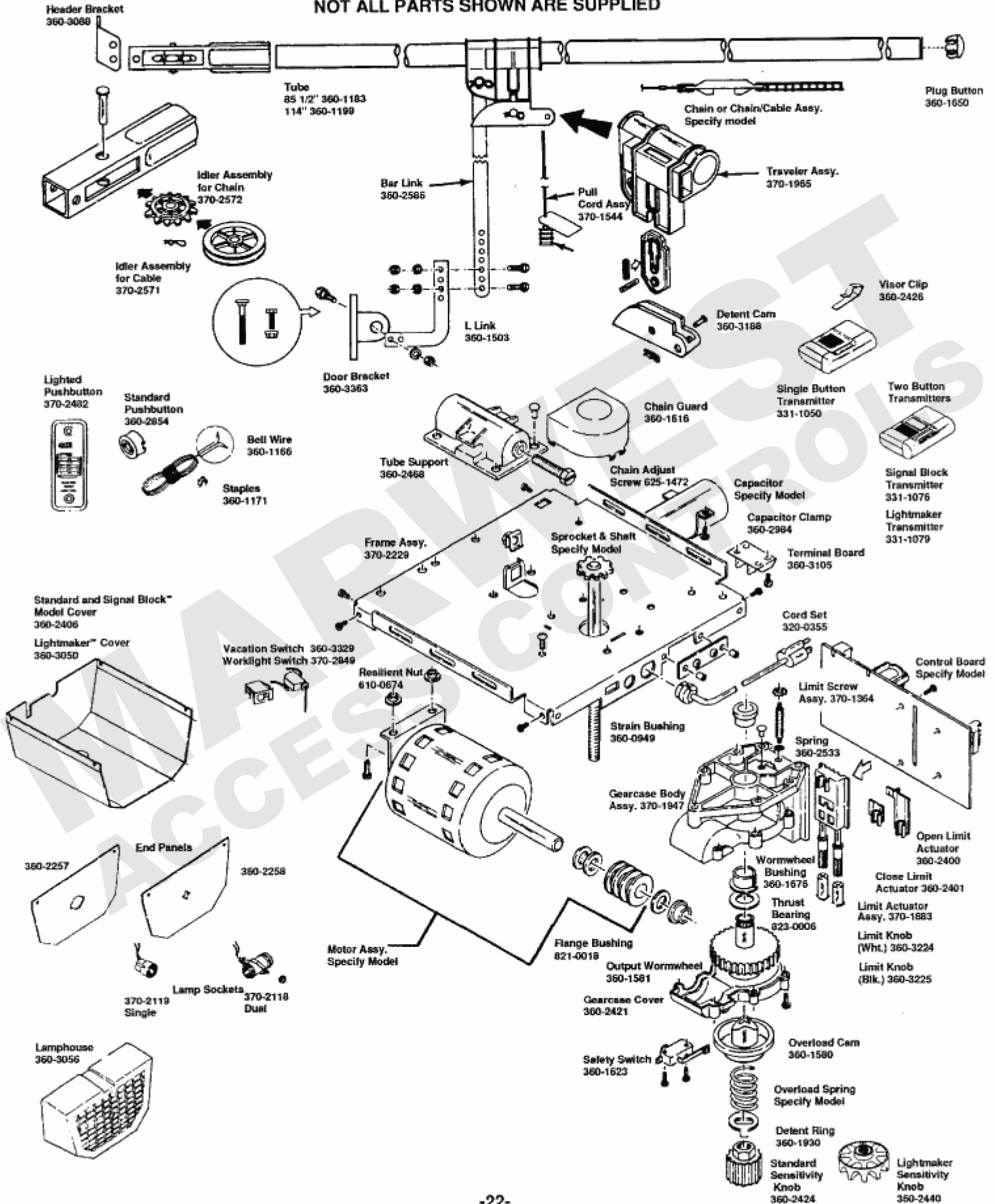

PARTS AND SERVICE

Your Stanley garage door opener has been designed and manufactured to offer you many years of trouble free service, convenience, and security. However, if a problem should occur:

1. Review the “**Homeowners Information & Safety Tips**” section in the front of this manual.
2. Read the “**Trouble Shooting**” section in the preceding pages to possibly identify the problem.

If after reviewing these two sections the problem cannot be solved, refer to the **Stanley Professional Dealer List** provided with the unit, or see your yellow page listing for **STANLEY** under the following headings:

DOOR OPERATING DEVICES

GARAGE DOOR OPENERS

GARAGE DOORS AND/OR GARAGES

**YOUR LOCAL STANLEY DEALER LISTED
ON THE BACK OF THIS MANUAL**

Your local **STANLEY DEALER** stocks parts and accessories to quickly repair your opener and keep it operating safely.

BEFORE CALLING, please locate the **MODEL NUMBER** and **DATE CODE** to ensure faster service. Refer to the “**PARTS LIST**” on the preceding page if a component is required.



CAUTION:

Contact your Stanley Dealer immediately if a malfunction is observed, or if the Safety Reverse System is not working properly.

Always keep transmitters out of the reach of children.

STANLEY

®

HOME AUTOMATION

A Division of The Stanley Works

For Your Records:

DATE PURCHASED _____

WHERE PURCHASED _____

MODEL NUMBER _____

DATE CODE _____

DATE INSTALLED _____

DO NOT THROW THIS MANUAL AWAY !

Keep In Garage For Future Reference

For technical questions or to place orders by phone, please call us at (800)849-3998 Mon-Fri 9am-5pm & Saturdays 9am-1pm Pacific Time, international calls use (818)725-7125

www.stanley-garage-opener.com